

RHINO

AUTOMATION FOR SWING GATES

Installation and User manual

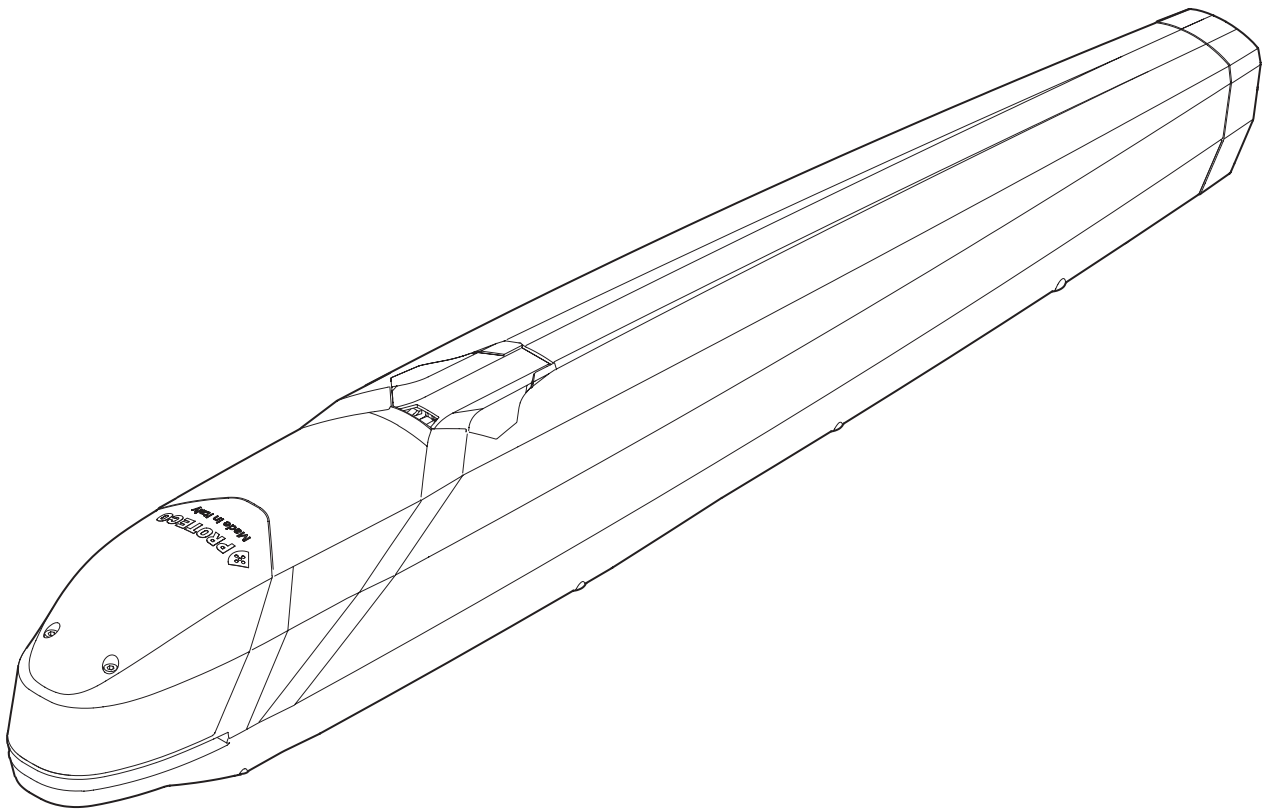



INDEX

| | |
|---|-----------|
| 1. WARNINGS | 4 |
| 2. DESCRIPTION AND INTENDED USE | 5 |
| 2.1 CONTENT | 5 |
| 3. TECHNICAL FEATURES | 5 |
| 3.1 MOTOR DIMENSIONS | 5 |
| 4. LIFE LINE | 6 |
| 5. INSTALLATION | 6 |
| 5.1 INTRODUCTION | 6 |
| 5.2 PRELIMINARY CHECKS | 6 |
| 5.3 INSTALLING THE OPERATOR | 7 |
| 5.4 OPENING MECHANICAL LIMIT SWITCH | 9 |
| 5.5 UNLOCKING THE MOTOR | 9 |
| 6. WIRINGS | 10 |
| 6.1 CHARACTERISTICS OF THE POWER CABLE CONNECTING THE CONTROL UNIT TO MOTOR TERMINAL | 10 |
| 7. END USER SECTION | 12 |
| 7.1 WARNINGS | 12 |
| 8. MAINTENANCE | 13 |
| 9. WARRANTY | 13 |
| 10. DISPOSAL | 13 |

1. WARNINGS

This manual for MATRIX series contains important information concerning personal safety. An incorrect installation or an improper use may lead to severe injuries.

Read carefully and pay particular attention to the safety sections marked by the yellow triangle 

 Make sure the main power line is equipped with state of the art safety grounding system.

 The installation of automatic doors, gates and barriers must comply with the Machinery Directive 2006/42/CE and EN 12453 regulation, and performed by qualified personnel.

 Make sure the whole installation is protected by a power cut switch and against overcurrent.

Make sure the area is clear from flammable gases and/or electromagnetic interferences: it could lead to very dangerous injuries.

 Switch the power and batteries OFF before any operation.

After installation, packaging and waste materials (cardboard, plastic, metal parts etc.) must be kept away from children as they could be potentially harmful.

Use only original spare parts. Any alteration to the system is prohibited.

Proteco Srl will not respond in case of using additional and/or fake spares.

 Before commissioning the system, deliver the last pages of this manual to the user (section 7. END USER'S TIPS).

Proteco S.r.l. reserves the right to make changes to the product without notice.

2. DESCRIPTION AND INTENDED USE

All models guarantee the mechanical locking of the gate with an irreversible gear system; therefore, it is not necessary to install any type of lock for gates up to 2.3 meters.

For longer leaves, an electric lock is recommended.

In the event of a blackout, the gearmotor can be manually unlocked. (See page 9 for Manual Operation).

2.1 CONTENT

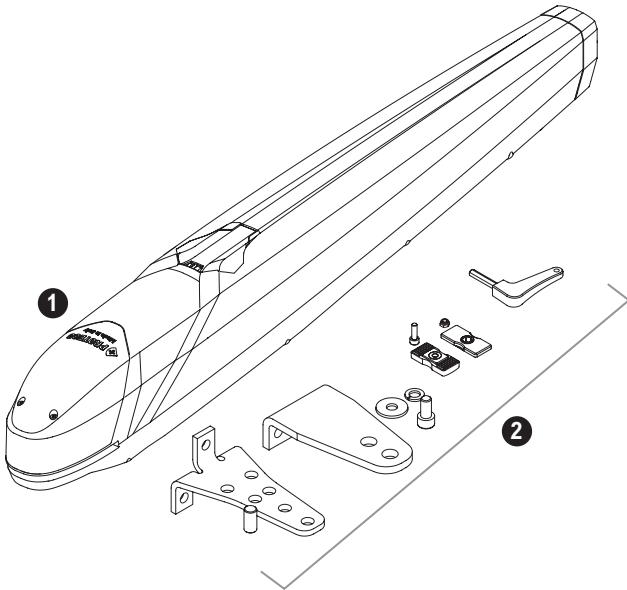

| | DESCRIPTION | ITEM | Q. |
|---|---|-----------|----|
| 1 | Swing operator RHINO | | 1 |
| | PILLAR BRACKET RH/LH T3 (galvanized 6 holes) | MPIP10Z | 1 |
| | GATE BRACKET (galvanized) | SPIA0670 | 1 |
| | Mechanical limit switch aluminium upper plate | MFPI02 | 1 |
| | Mechanical limit switch aluminium lower plate | MFPI01 | 1 |
| | PIN 12x24 | MPE1224 | 1 |
| 2 | SCREW TCEI 8.8 M 10x20 galvanized -UNI5931- | MVI1020CZ | 1 |
| | Galvanized elastic washer Ø10 UNI 1751 | MRO10EZ | 1 |
| | SELF LOCKING BOLT M5 DIN 985 | MDAM05AB | 1 |
| | SCREW TCEI 5x14 INOX -UNI5931- | MVI0514CI | 1 |
| | GALVANIZED WASHER 10,5x30 2,5 | MRO1030Z | 1 |
| | RELEASE KEY | SCH0190 | 1 |

3 TECHNICAL FEATURES

| | RHINO 230V | RHINO 115V | RHINO 24V |
|--------------------------|-------------|-------------|-----------|
| Power supply | 230V ~ 50Hz | 115V ~ 60Hz | 24V dc |
| Motor voltage | 1.2 - 1.7A | 3.1 - 3.3A | 0.6 - 6A |
| Rated power | 300 W | 300 W | 50 W |
| Thermal cut off | 150°C | 150°C | -- |
| Rated thrust | 3200 N | 3200 N | 2700 N |
| IP rating | 44 | 44 | 44 |
| Revolutions | 1400 rpm | 1700 rpm | 1600 rpm |
| Opening time without MLS | 26" | 22" | 24" - 28" |
| Opening time with MLS | 22" | 18" | 20" - 24" |
| Duty cycle | 40% | 40% | 80% |
| Cycles per hour | 20 | 20 | 36 |

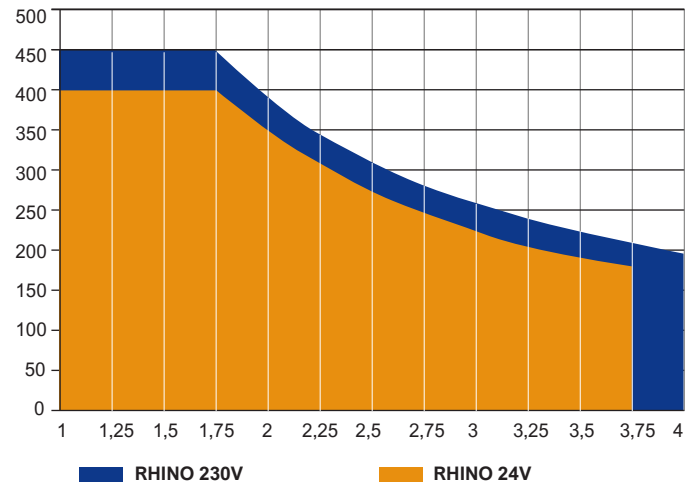

3.1 MOTOR DIMENSIONS

PIN DISTANCE: OPEN – CLOSED **Without**

MLS (mechanical limit switch)

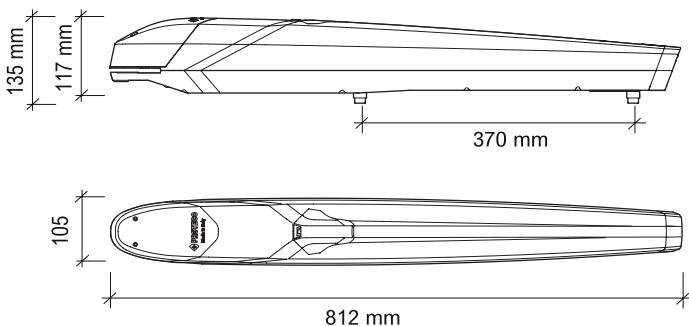

With MLS (mechanical limit switch)

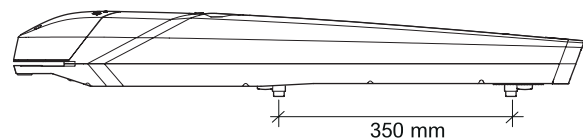

4 LIFE LINE

The life of the gearmotor may be affected by multiple waste factors. The life expectation can be calculated using the criteria outlined in the below table.

In order to get the waste rate add together all values in *Table 1C* that comply with the installation scenario and according to the accessories fitted.

ATTENTION:

If the waste rate obtained is beyond 10, move to a superior version in order to fulfill the expected performances.

Follow the waste rate line of the graph (*Table 1A* or *Table 1B*) to get the estimated duty cycles.

Duty cycles obtained may be compromised if the maintenance plan is not carefully respected.

Duty cycles are determined on the base of design analysis, project calculations and tests carried out at factory for a 90° opening.

Therefore the duty cycles achieved are a mere estimation.

The value obtained from the sum of the variants will be a number between 0 and 10 and will indicate the waste rate (*Table 2*) to be used on the graph to verify the durability of the product.

TABLE 1A

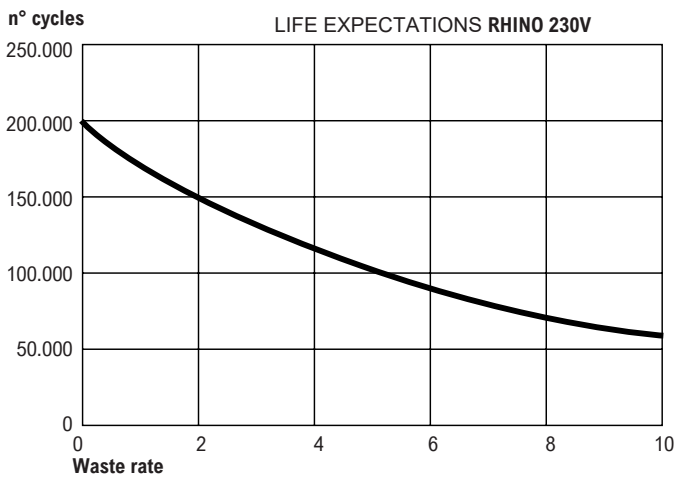

TABLE 1B

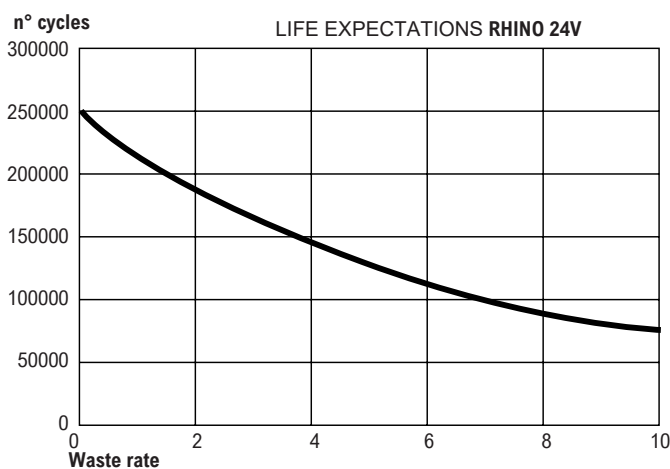



TABLE 1C

| | RHINO 230V | RHINO 24V |
|--|------------|-----------|
| Leaf max 1,5 m | 1 | 1 |
| Leaf max 2 m | 1,5 | 1 |
| Leaf max 2,5 m | 2,5 | 1,5 |
| Leaf max 3 m | 3 | 2,5 |
| Leaf max 3,5 m | 3,5 | — |
| Weight max 200 Kg | 1,5 | 1 |
| Weight max 250 Kg | 2 | 1,5 |
| Weight max 300 Kg | 2,5 | 2,5 |
| Weight max 350 Kg | 3 | 3 |
| Strong wind | 3 | 3 |
| Panelled leaf | 1,5 | 1,5 |
| Outside temperature over 40° or lower 0° | 1 | 1 |

5. INSTALLATION

5.1 INTRODUCTION

ATTENTION!
 The installation must be carried out by qualified personnel, in compliance with laws, regulations, and what is reported in these instructions.

ATTENTION!
 Any use other than that described and in environmental conditions different from those reported in this manual is to be considered improper and prohibited.

To correctly perform the installation follow in sequence all the steps indicated in this chapter

5.2 PRELIMINARY CHECKS

Before proceeding to installation, it is necessary to double check the good condition of every component and make sure the site is suitable for installation purposes.

- All components must be integral and suitable to use.
- Make sure the installation site complies with system's dimensions.
- Make sure weight, dimensions and gate features are suitable to the model you have chosen.
- Make sure the gate area is fitted with ground stops both in opening and closing.
- Make sure the gate is mechanically free of friction.
- Make sure the automation fixing area is compatible with the dimension of the brackets and there is sufficient space to carry out manual operation easily and safely.
- Make sure the automation positioning area is not subject to flooding;
- Make sure the electric circuit is connected to a state of the art safety grounding.
- Make sure the fixing surfaces of the photocells are flat and allow correct alignment between transmitter and receiver.

5.3 INSTALLING THE OPERATOR

INSTALLATION QUOTA

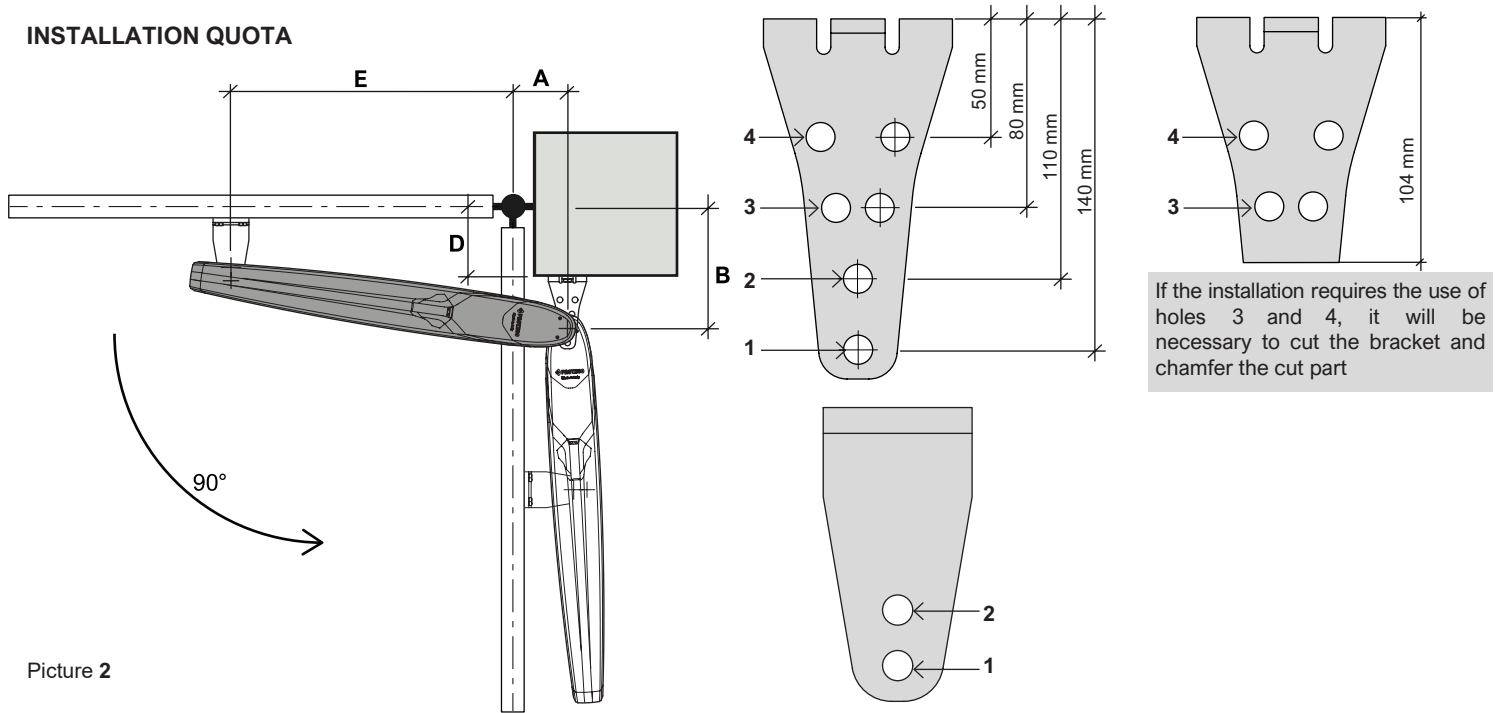

Picture 2

| Opening 90° | | | | | | | | |
|---------------------|-----|-----|-----|-----|-----|-----|-----|-----|
| D | 175 | 150 | 125 | 100 | 75 | 50 | 25 | 0 |
| A | 95 | 120 | 140 | 120 | 120 | 120 | 120 | 120 |
| B | 255 | 230 | 205 | 210 | 185 | 160 | 135 | 140 |
| E | 605 | 590 | 570 | 580 | 585 | 580 | 580 | 585 |
| Pillar bracket hole | 3 | 3 | 3 | 2 | 2 | 2 | 2 | 1 |
| Bracket quote | 80 | 80 | 80 | 110 | 110 | 110 | 110 | 140 |
| Max opening angle | 90 | 90 | 90 | 95 | 95 | 95 | 95 | 95 |
| Front hole | 2 | 1 | 1 | 2 | 2 | 2 | 2 | 2 |

| Opening 100° | | | | | | |
|---------------------|-----|-----|-----|-----|-----|-----|
| D | 125 | 100 | 75 | 50 | 25 | 0 |
| A | 135 | 140 | 145 | 145 | 150 | 150 |
| B | 205 | 180 | 155 | 160 | 135 | 140 |
| E | 575 | 575 | 565 | 560 | 555 | 555 |
| Pillar bracket hole | 3 | 3 | 3 | 2 | 2 | 1 |
| Bracket quote | 80 | 80 | 80 | 110 | 110 | 140 |
| Max opening angle | 100 | 105 | 110 | 110 | 115 | 115 |
| Front hole | 2 | 1 | 2 | 2 | 2 | 2 |

BRACKET DISTANCE AND LEVELING

Picture 3

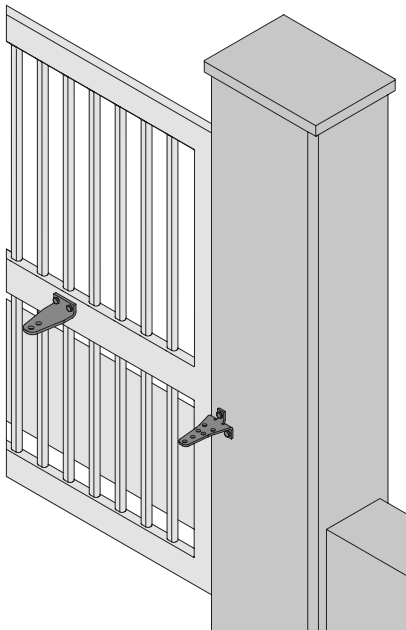

Picture 4

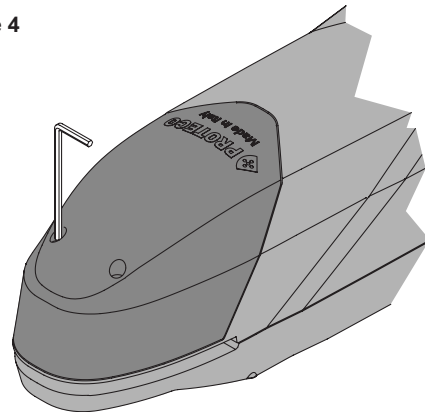

Picture 5

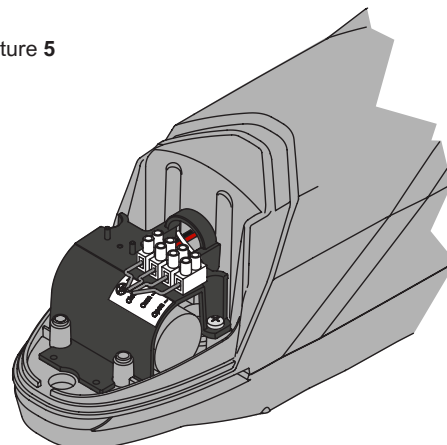

During the bracket positioning, remove the plastic cover from motor terminal, see pictures 4 and 5. Unlock the motor (picture 15).

Fit the brackets complying with the installation quota.
Keep a **49 mm** gap between the pillar and the gate bracket.

Picture 8

Picture 6

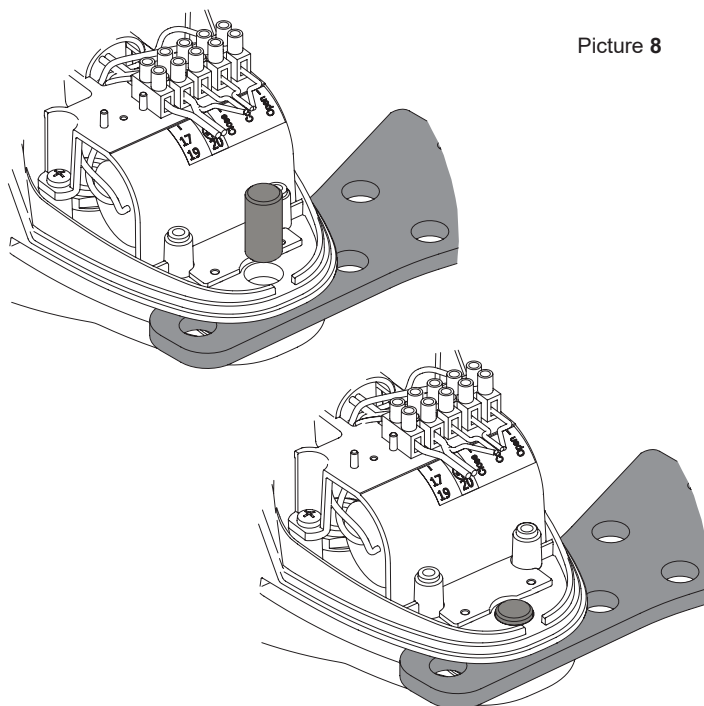
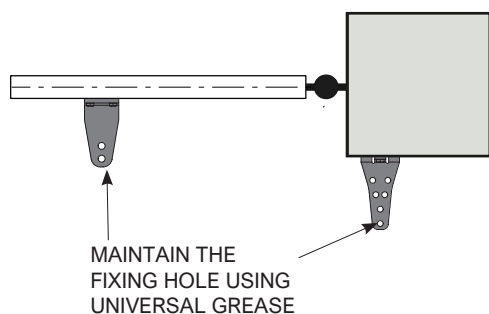
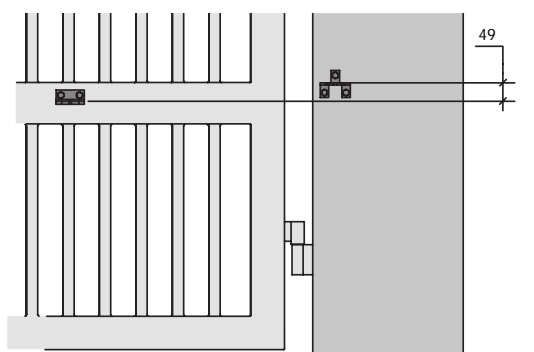

2) Insert the drag pin into hole 1 or 2 of the gate bracket and fit washer and screw in sequence as shown in picture 9 and 10

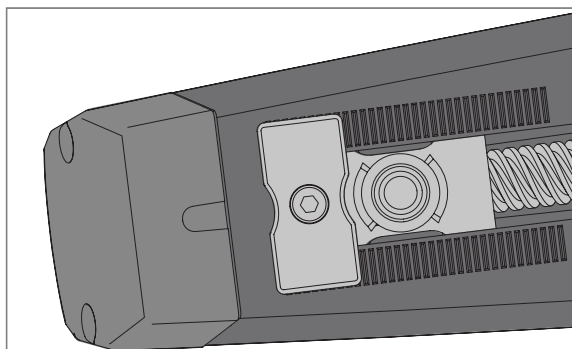

Note:
The mechanical closing limit switch is factory-mounted in its maximum position, and it is recommended to keep it during installation.
Generally, the gate is equipped with a closing ground stop. In this case, when the installation is completed, you can remove it; otherwise you can use it to adjust the desired position

Picture 9

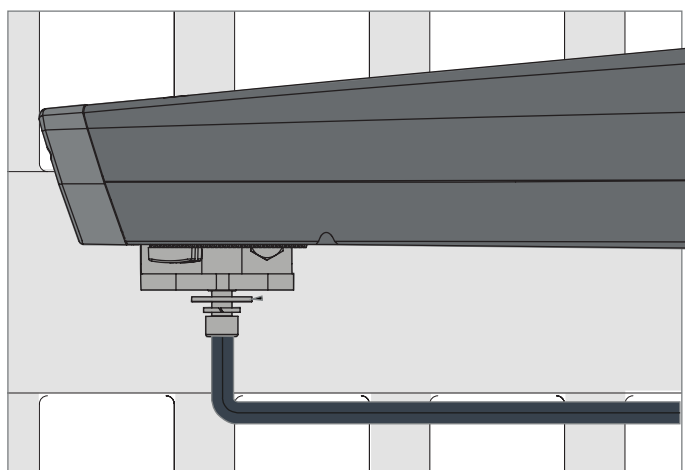

1) Insert the MPE1224 fork pin into the hole of the pillar bracket choosing the hole that best suits the installation, pictures 7 and 8

Picture 7

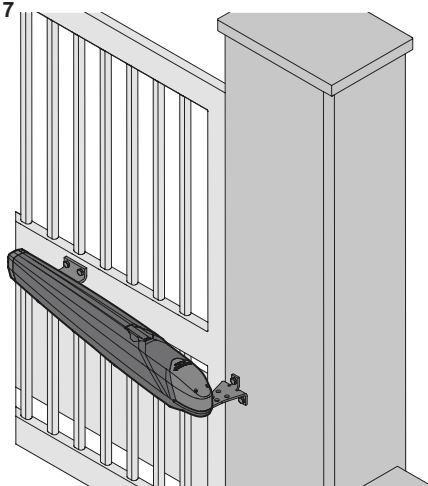

Picture 10

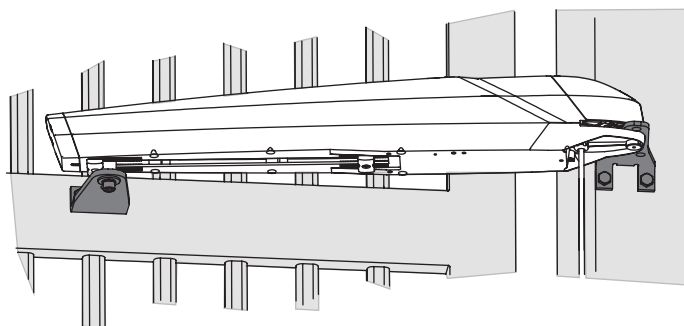

5.4 ADJUSTING THE OPENING MECHANICAL LIMIT SWITCH.

- Follow the sequence outlined in Picture 11 to assemble the limit switch.
- Partially turn the plate according to Picture 12, to help the assembly.
- Fit the limit switch inside the RHINO buttonhole.
Turn **plate A** (Picture 14) in a way that **plate A and B** match properly, refer to Picture 13.

Unlock the motor and open the gate to the desired opening position.
Fix the opening position closing screw M5 until both plates are firmly locked.
The plates shall pair the RHINO toothed metal case (Picture 14)

Picture 11

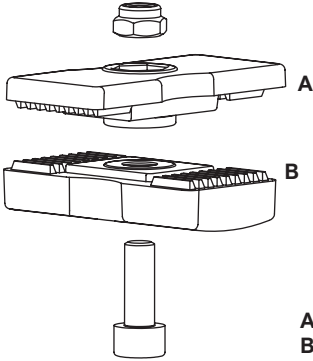

Picture 12

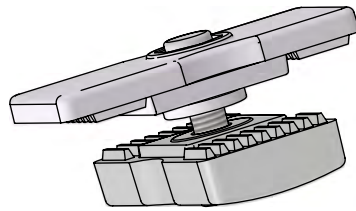

A = Upper plate
B = Lower plate

Picture 13

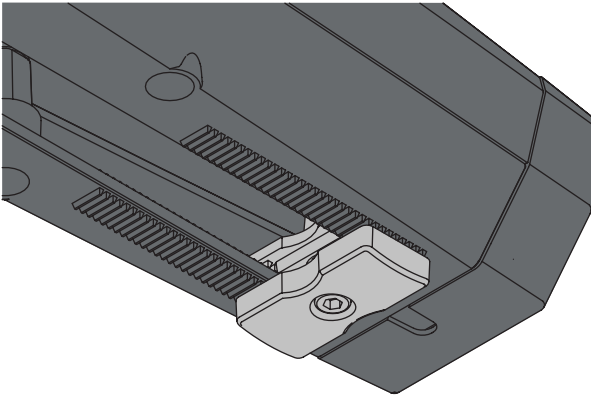

The limit switch assembly has a tread of **2 mm** for a distance of approximately **60 mm** (Picture 14)

Picture 14

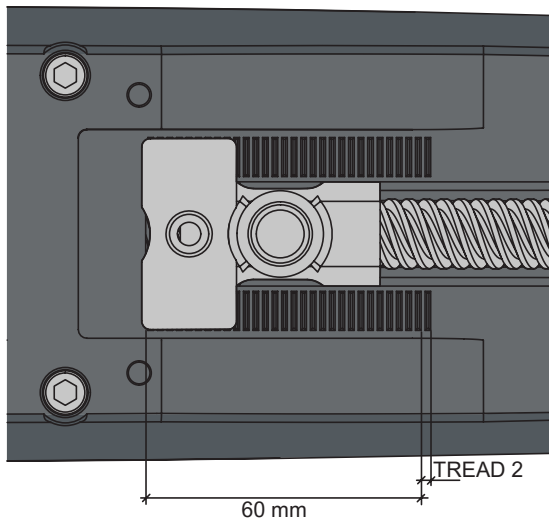

5.5 UNLOCKING THE MOTOR

Lift and hold the plastic flap (Picture 15), plug the release key **SCH0190** in the exagonal slot, rotate about 90° clockwise in order to unlock and viceversa to lock back.

Picture 15

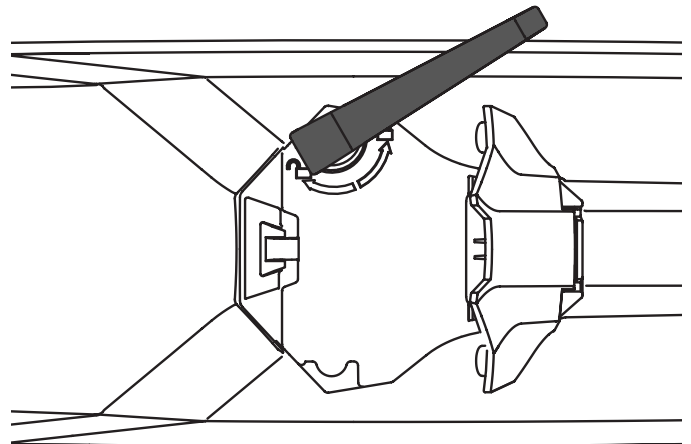
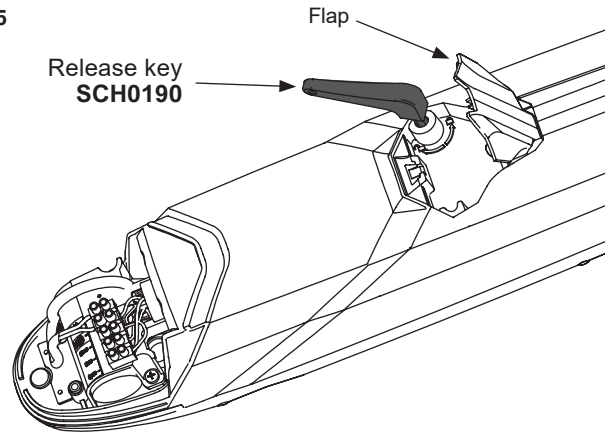

6 WIRINGS

- All connections must be made without power. Switch the power OFF.
- Fit a device (e.g. thermomagnetic switch) that cuts electrically the system from the main power supply. The standards require a contact separation of at least 3 mm for each pole (EN 60335-1).
- Installation requires electrical and mechanical skills; must be carried out only by qualified personnel able to provide declaration of conformity type A on the whole installation (Machinery Directive 2006/42/EEC, Annex IIA).
- The main electrical circuit must also comply with current regulations and be carried out state of the art.
- The power lines to the motors, control unit and accessories must be separated to avoid interferences that could cause malfunction of the system.
- The power cable wired to the motor terminal has to make a wide downward bend to avoid the backflow of water inside the motor itself.

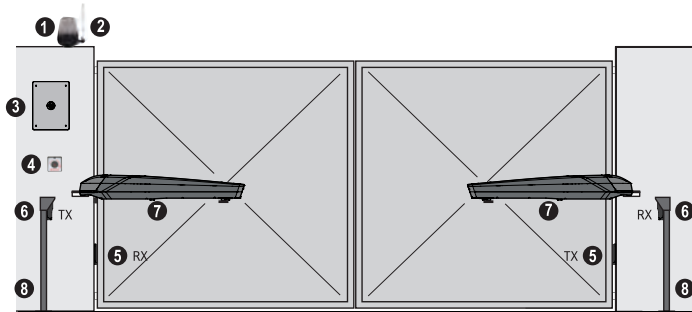

1_Flashing light 2_Antenna 3_Control unit 4_Key switch
5_CLOSING photocell 6_OPENING photocell
7_Motors 8_Phocell pillar

NB: Cables necessary for the installation of the system (not included) may vary according to the quantity and type of accessories and devices fitted.

6.1 CHARACTERISTICS OF THE POWER CABLE CONNECTING THE CONTROL UNIT TO MOTOR TERMINAL

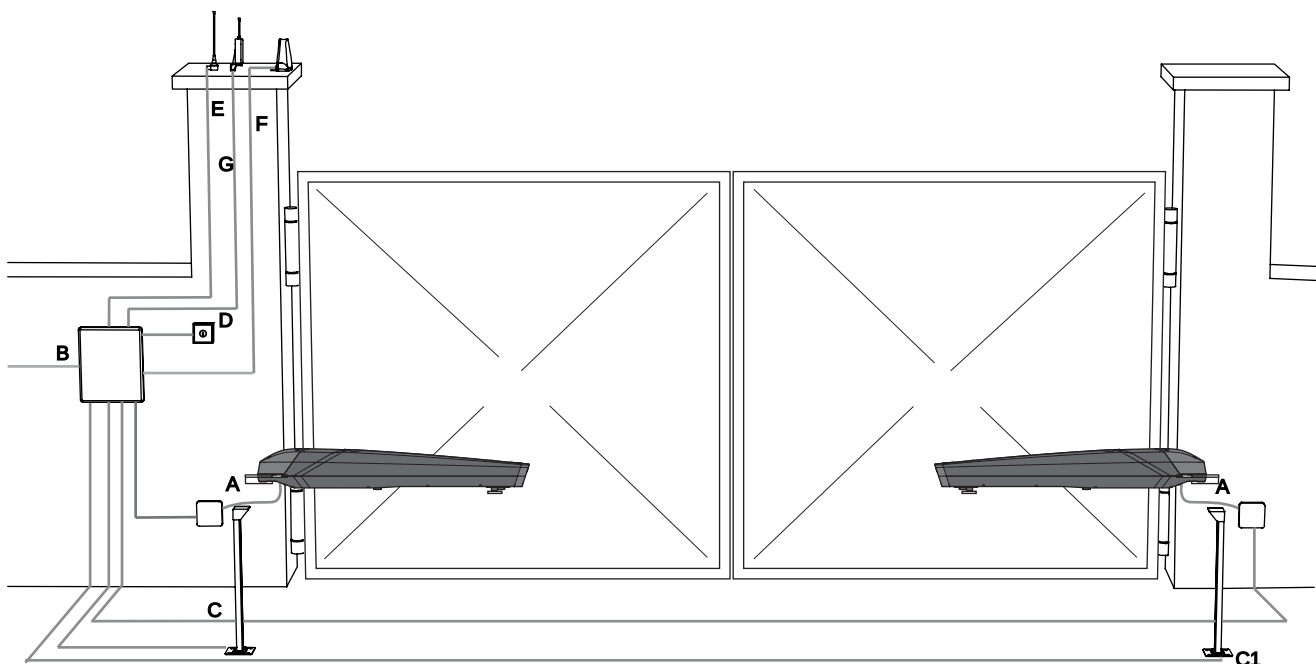

Power supply from control unit to motor terminal

| | version 230V/115V | version 24V |
|-------------------------|---------------------------------|-------------------------------|
| B Control unit | 2 x 1,5 mm ² + Earth | 2 x 1 mm ² + Earth |
| C Photocell RX | 4 x 0,5 mm ² | 4 x 0,5 mm ² |
| G Photocell TX | 2 x 0,5 mm ² | 2 x 0,5 mm ² |
| D Key switch | 2 x 0,5 mm ² | 2 x 0,5 mm ² |
| E Antenna | RG58 | RG58 |
| F Flashing light | 2 x 0,5 mm ² | 2 x 0,5 mm ² |
| G Radio receiver | 2 x 0,5 mm ² | 2 x 0,5 mm ² |

A Cable type:

- For power supply **230V** and outdoor use, choose cable type H05RN-F complying with 60245 IEC 57 (IEC); for indoor use, choose cable type H05VV-F complying with 60227 IEC 53 (IEC).
- For power supply up to **48V**, choose cable type FROR 20-22 II complying with EN 50267-2-1 (CEI)

ATTENTION: maximum cable diameter 8 mm

For 230V type H05RN-F 4Gx0,75 mm²

For 24V type H05RN-F
or FROR 20-22 2x1 mm²

VERSION 230 V/115V

Insert the cable through the cable gland

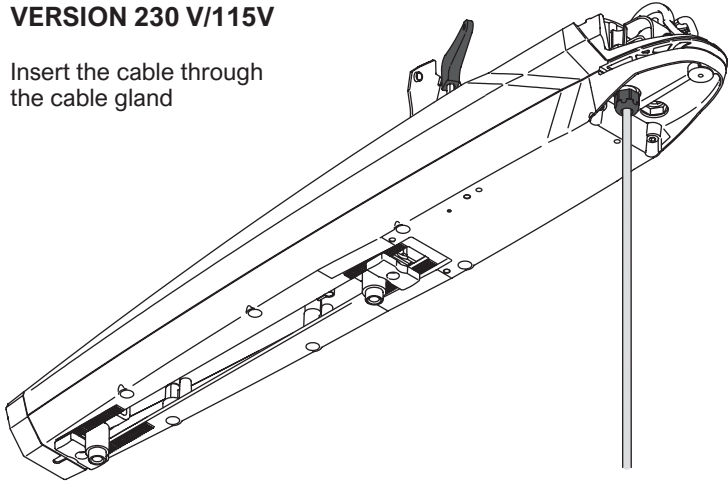

VERSION 24 V

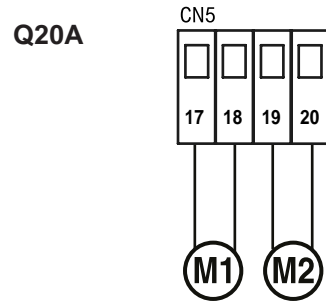
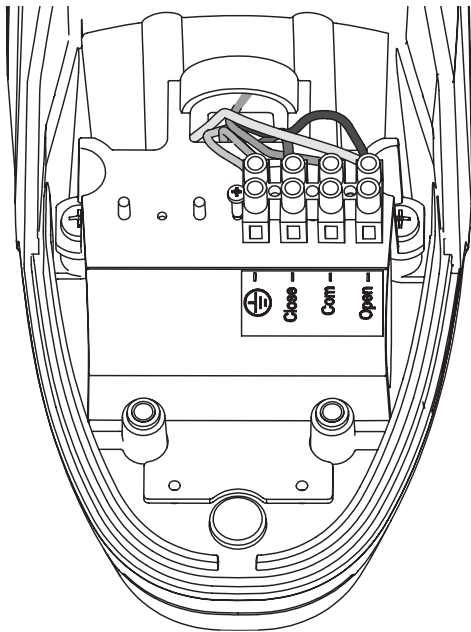
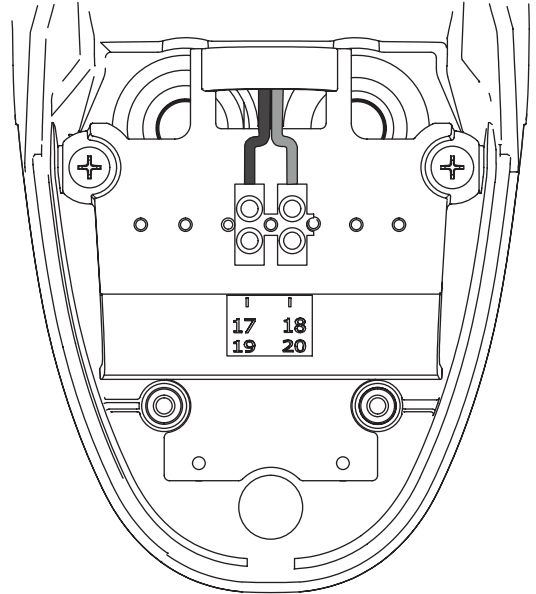

Wire the motor to the control unit respecting the correct terminals.

Capacitors are prewired and stowed underneath the motor terminal compartment.

Q80A

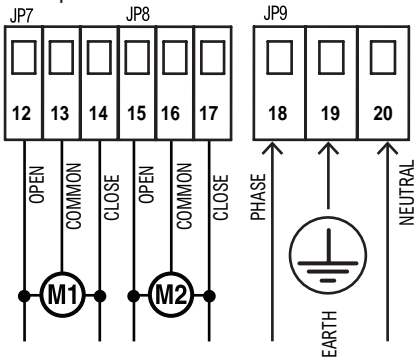

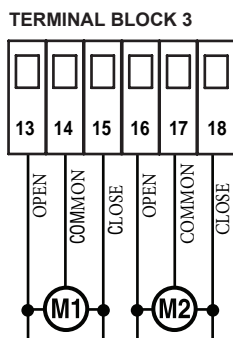

Q60A







7 END USER GUIDELINES

The following pages contain important information for your safety and for complying with standing safety regulations. Keep this manual for future reference.

7.1 SAFETY TIPS

-  Keep children under 8 away from the system.
-  Do not access, for any reason, the internal parts of the automation: it may be dangerous and components can only be repaired or replaced by qualified personnel.

-  Children over 8, people with reduced physical or mental abilities, or lacking experience, may only use the automation under supervision, or if they have been instructed on how to use safely the system and have understood the related dangers.
-  Do not start transmitters or other command devices unless the area is visible and clear from danger.

-  This product was designed and built exclusively for the intended use indicated. Any other use could compromise the integrity and safety of the product and should be avoided.
-  Do not allow children play within the automation area.

| DATE | NOTES | INSTALLER SIGNATURE | OWNER SIGNATURE |
|------|-------|---------------------|-----------------|
| | | | |
| | | | |
| | | | |
| | | | |
| | | | |
| | | | |
| | | | |
| | | | |
| | | | |
| | | | |
| | | | |
| | | | |
| | | | |
| | | | |
| | | | |
| | | | |
| | | | |
| | | | |
| | | | |
| | | | |
| | | | |
| | | | |
| | | | |
| | | | |
| | | | |
| | | | |
| | | | |
| | | | |
| | | | |
| | | | |
| | | | |
| | | | |
| | | | |

8 MAINTENANCE

ATTENTION!

Maintenance of the automation must be carried out by qualified technical personnel, in full compliance with the safety regulations established by current laws.

To keep the automation safety and in good operation over time, it is advisable to schedule a periodic maintenance plan and carry out the following inspections:

- Disconnect any electrical power source.
- Check the waste condition of all components that make up the automation.
- Check the gate bracket fixing screws and in case the mechanical limit switches.
- Check that screw connections are tightened properly.
- Unlock and check the correct manual operation in opening and closing.
- Put the gate to the closing position, lock the automation and carry out the programming procedure again, if necessary.

Checking the release system

- Check the efficiency of the release system: put the gate to closing position, unlock the system and make sure the release operation is smooth.
- Make sure the gate moves permanently free, clear of any friction points.

9 WARRANTY

PROTECO products are covered by a 3-year limited warranty from the manufacturing date stuck on the product.

In this period, Proteco Srl responds for malfunction due to construction faults, faulty parts or faulty assembly.

The guarantee is liable only if use, maintenance and instructions have been duly complied.

This warranty does not respond if fake spare parts are used or if fault is due to incorrect installation or force majeure conditions. Installation and maintenance are entirely at the installer care and responsibility.

Under no circumstances and in no way Proteco Srl will be liable for damages, loss of profits, savings or other accidental or indirect damages, deriving from the use or from the inability to use PROTECO products.

Any return without a return authorization number will be rejected. Shipping of the returned product and related costs are responsibility of the buyer.

All defective products must be returned together with proof of purchase to:

PROTECO Srl Via Neive 77, 12050 Castagnito (CN) - Italia

Warranty is void when:

- The product has been handled/stored under improper conditions of use and maintenance.
- The product has been repaired, modified or altered.
- The product has been subjected to misuse, negligence, electrical problems, storage in improper packaging, accident or natural events.
- The product was installed improperly.
- The product warranty label is illegible or completely missing.
- The malfunction is due to improper installation or natural and/or accidental causes (e.g. falls, oxidation, overvoltage).

When returning a product, remember to include in addition all your data (name, surname, address, telephone number and/or e-mail) to allow us to contact you and update you on your return procedure.

10 DISPOSAL

Disposal of the system

Any part of the system, including devices such as remote controls, must be disposed in compliance with current legislation, as they may be harmful for the environment.

Most of the materials used are similar to solid urban waste and can be handled accordingly.

They can be recycled through separate collection and disposed in authorized centers.

Other components (electronic boards, batteries, etc.) may instead contain polluting substances.

They must therefore be removed and delivered to companies authorized for their recovery and disposal.

Before proceeding, it is always advisable to check the specific regulations in force.

Disposal of packing

Packaging components (cardboard, plastics, etc.) are similar to solid urban waste and can be handled accordingly without any difficulty, simply by carrying out separate collection for recycling. Before proceeding, it is always advisable to check the specific regulations in force.

COMPLIANCE DECLARATION

The Manufacturer: **PROTECO S.r.l.**
Address: Via Neive, 77 - 12050 CASTAGNITO (CN) - ITALY

declares that

The product type: Automation for swing gates and according accessories **RHINO**
model: **RHINO**

Is built to be integrated into a machine or to be assembled with other machinery to create a machine under provisions of 2006/42/EC Machinery Directive.

It complies with the essential requirements of EEC Directives:

2011/65/CE (RoHS 2) + 2015/863/UE (RoHS 3)
2014/35/UE (LVD) Low voltage Directive
2014/30/UE (EMC) Electromagnetic compatibility Directive

The product also complies with:

EN12453,
EN55014-1, EN55014-2,
EN61000-6-1, EN61000-6-3 EN 60335-1,
EN 60335-2-103

The manufacturer declares that the start-up of the machinery is not permitted unless the machine, in which the product is incorporated or of which is becoming a component, has been identified and declared as conformed to 2006/42/EC Machinery Directive.

Note: These products were tested in a typical homogeneous configuration

Marco Gallo
CEO

Castagnito, 12th April 2024

