

DOLLY

GARAGE DOOR OPENER

Installation Manual

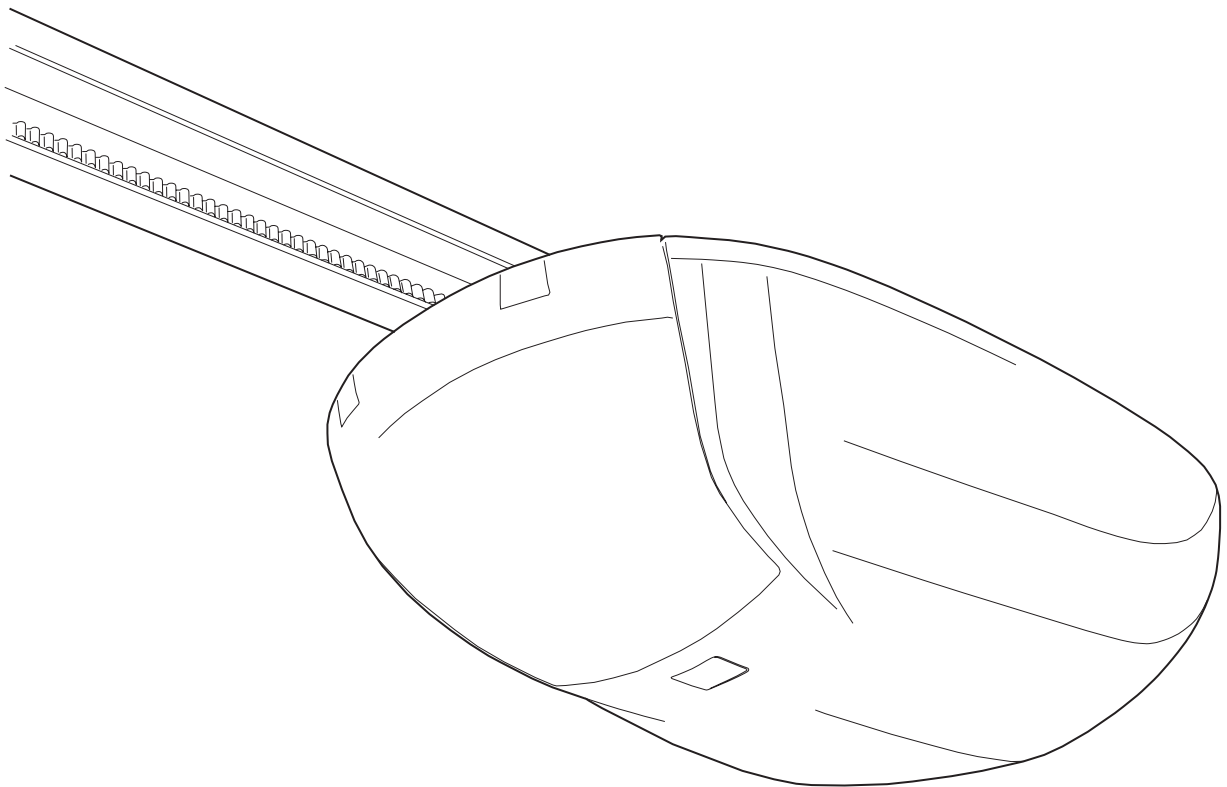



TABLE OF CONTENTS

1. SAFETY PRECAUTIONS	4
2. TECHNICAL SPECIFICATIONS	5
2.1 DIMENSIONS	5
3. BOX CONTENTS	5
3.1 OPENER PACK	5
3.2 RAIL PACK	5
4. STANDARD SETUP	6
5. 5. INSTALLATION	6
5.1 Assembling the rail	7
5.2 Fitting the belt tensioner	7
5.3 Fixing the wall bracket and the rail	7
5.4 Fitting the motor to the rail	9
5.5 Assembling tow brackets	10
5.6 Fixing the door bracket	10
6. COUNTER-WEIGHTS BALANCED OVERHEAD DOORS	10
7. MANUAL RELEASE	11
8. PROGRAMMING	11
8.1 Setting the door opening and closing position. Auto-setting of the lifting force	11
8.2 Saving/Deleting transmitters radio code	11
8.3 Start command	11
8.4 Reset to factory settings	12
8.5 Obstacle detection adjusting	12
8.6 Auto-closing	12
8.7 Enabling the photocells	12
9. WIRINGS	12
10. TROUBLESHOOTING	13
11. MAINTENANCE	13
12. INSTRUCTIONS FOR END USER	14
12.1 Warnings	14
12.2 Emergency Release	14
12.3 Maintenance Records	15
13. WARRANTY TERMS	16
14. DISMANTLING AND DISPOSAL COMPLIANCE DECLARATION	16

1. SAFETY PRECAUTIONS

This manual contains important safety instructions: incorrect or improper use of the opener can lead to personal harm or properties damages.

Please read the instructions fully and carefully.

Pay particular attention to paragraphs marked as  .

 Wire to mains by setting up a professional earthing system according to good professional practice.

 This product is defined by Machinery Directive 2006/42/EC and EN 12453 regulation. Qualified personnel must carry on installation of this product only. The final installation must comply with the following European regulations: EN 60204-1, EN 12453, EN 13241-1, EN 12635

 Make sure you have set up a suitable dual-pole cut off device and adequate protection system from surcharge events

Do not install in environments close to easily ignited materials, flammable gas or subject to electro-magnetic fields as they may represent a hazard to people safety

 Always disconnect the system from main power and/or backup batteries when performing maintenance, cleaning, replacement of parts or any kind of mechanical adjustment

Once the installation is completed make sure that all packaging and waste material (cardboard, plastic and metallic parts) are stored away from children as they may be dangerous.

In case of maintenance or repairing, use original manufacturer's spare parts only.

Use only original spare parts. Any alteration to the system is prohibited.

Proteco Srl will not respond in case of using additional and/or fake spares.

 Make sure to hand over to the end user all the operating manuals with particular reference to chapter 12. INSTRUCTIONS FOR END USER

Proteco Srl may change the contents of this manual at any time and without notice.

2. TECHNICAL SPECIFICATIONS

	DOLLY 600	DOLLY 1000	DOLLY 1200
Power supply	230V-50/60Hz	230V-50/60 Hz	230V-50/60Hz
Motor voltage	24V dc	24V dc	24V dc
Maximum power	200 W	245W	260W
Maximum traction force	600 N	1000 N	1200 N
Rated force	300 N	400 N	450 N
Maximum door area	10 m ²	14 m ²	16 m ²
Maximum door weight	100 kg	140 kg	160 kg
Maximum continuous operating time	4 min ON 36 min OFF	4 min ON 36 min OFF	4 min ON 36 min OFF
Cycles/hour (max)	20	15	13
IP protection rating	20	20	20
Working temperature	-20°C ++ 40°C	-20°C ++ 40°C	-20°C ++ 40°C
Radio frequency	433,92 MHz	433,92 MHz	433,92 MHz
Radio code storage	40	40	40
Relative humidity rate	<90%	<90%	<90%

2.1 DIMENSIONS

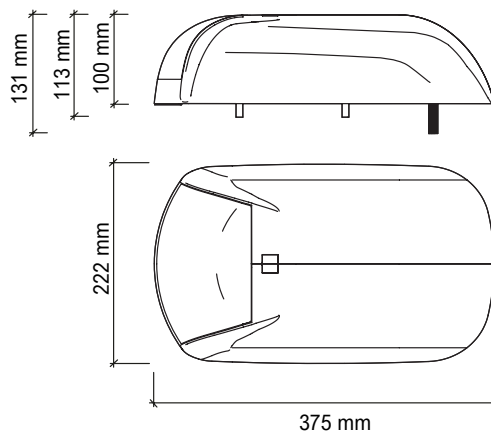

3. BOX CONTENTS

3.1 OPENER PACK

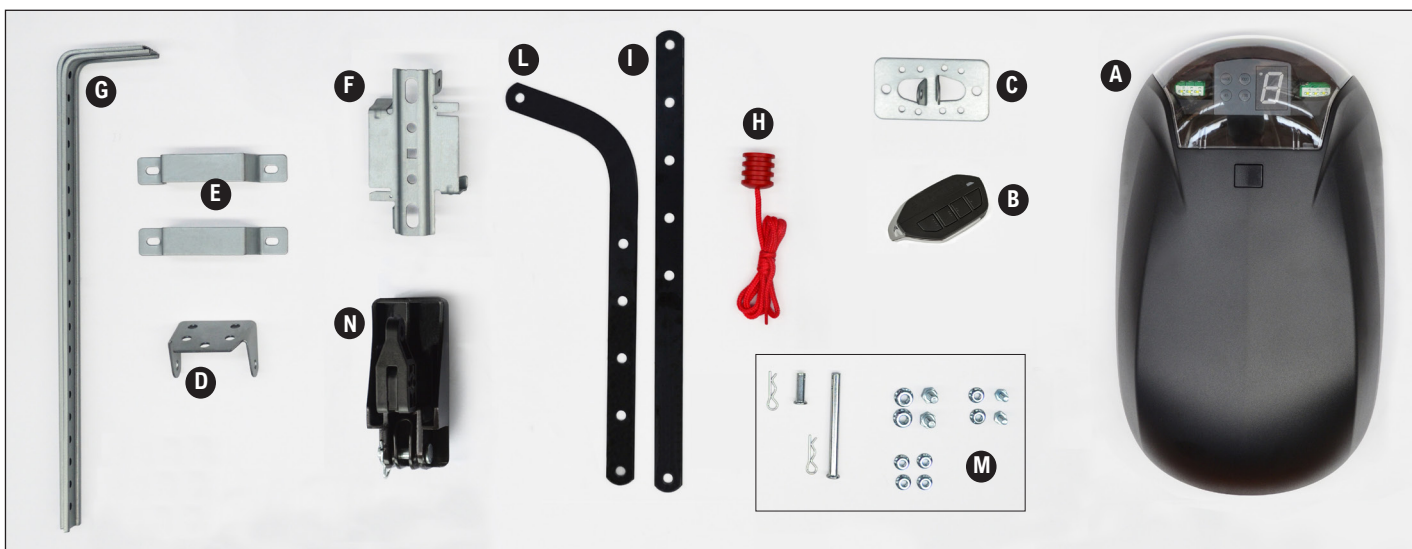

ITEM	QUANTITY
A OPENER	1
B REMOTE CONTROL	1
C DOOR BRACKET	1
D WALL BRACKET	1
E "U" BRACKET	2
F RAIL BRACKET	1
G CEILING BRACKET	2
H RELEASE CORD AND KNOB	1
I STRAIGHT TOW BRACKET	1
L CURVED TOW BRACKET	1
M FIXING ACCESSORIES BAG	1
N TROLLEY	1

ITEM	QUANTITY
O RAIL CONNECTOR	1
P RAIL SEGMENT B	1
Q RAIL SEGMENT C	1
R BELT	1
S MOTOR-RAIL ADAPTER	1
T BELT TENSIONER	1
U SKID	1
V PULLEY	1
X FIXING BRACKET	1

3.2 RAIL PACK MDLR01-MDLR02-MDLR03

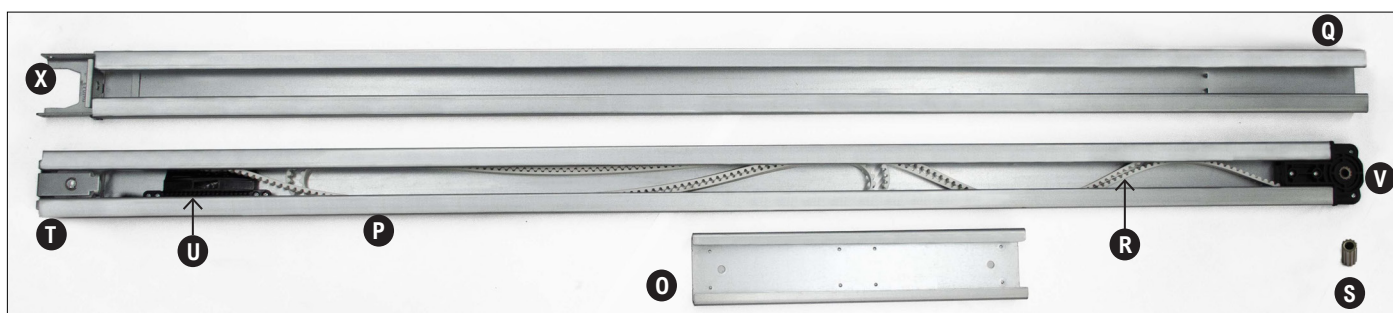

4. STANDARD SETUP

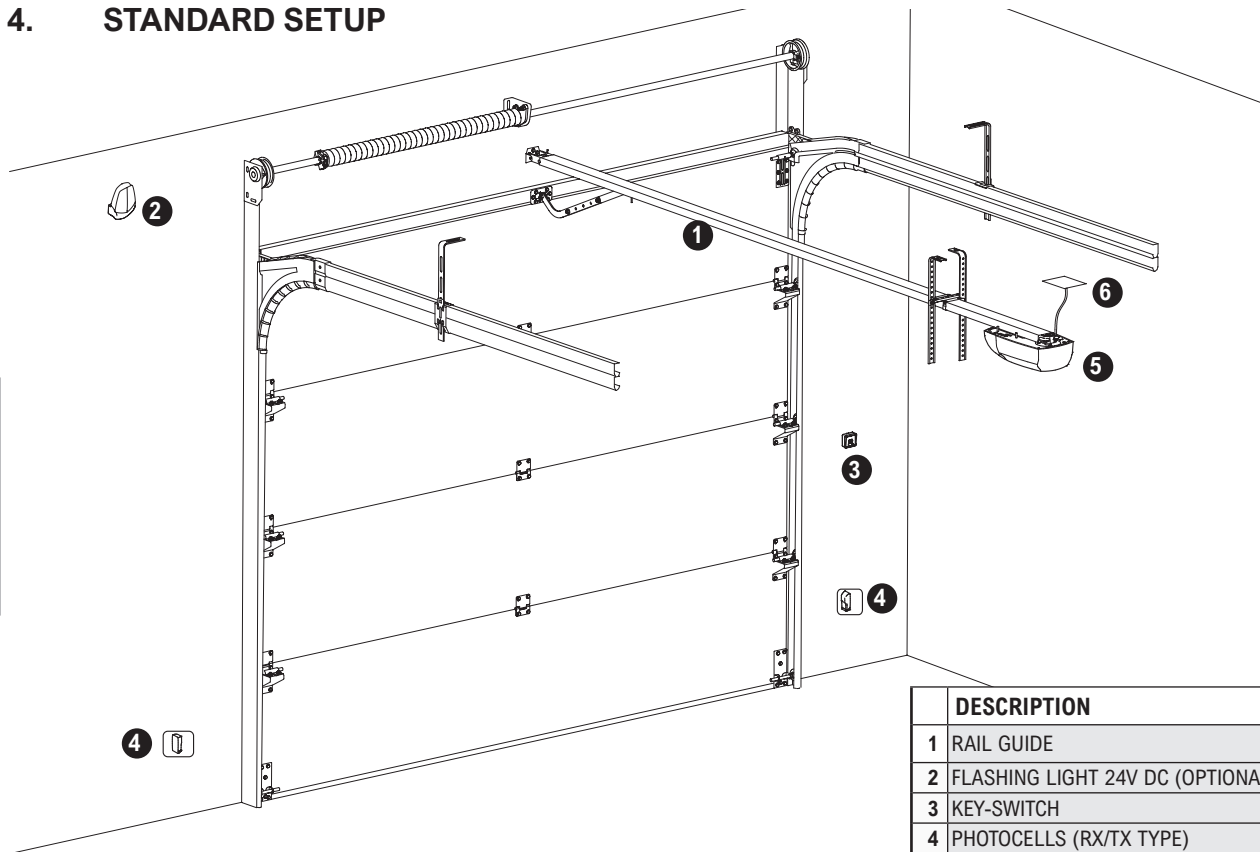

The illustration shows an example of standard automation system, using Proteco components

	DESCRIPTION
1	RAIL GUIDE
2	FLASHING LIGHT 24V DC (OPTIONAL)
3	KEY-SWITCH
4	PHOTOCELLS (RX/TX TYPE)
5	OPENER
6	MAINS PLUG

5. INSTALLATION

Please keep in mind that installing an automatic opener does not compensate for improper fitting of the door or lack of maintenance. Before proceeding, make sure that the door itself is in good conditions and complies with regulations currently in force

- Make sure that the door's frame is solid and suitable for automation.
- The door must be equipped with fall arrests (independent from suspension system).
- The door must open and close safely and smoothly, without any friction point, when manually operated.

- Make sure that the door is well balanced by testing the following: stop the door in any position mid-way when opening or closing and check if the door stays still in this position; in case the door moves up or down please adjust spring-system or counter-weights accordingly.
- Please use suitable fixing tools and supplies to anchor the opener and rail.
- If needed, perform a suitable structural analysis of the system and add it to the technical dossier of the system.
- In case of protruding/retracting overhead door you must keep at least 20 mm distance between the upper edge of the door and the rail of the opener.

Sectional door type: Max H = 2600mm

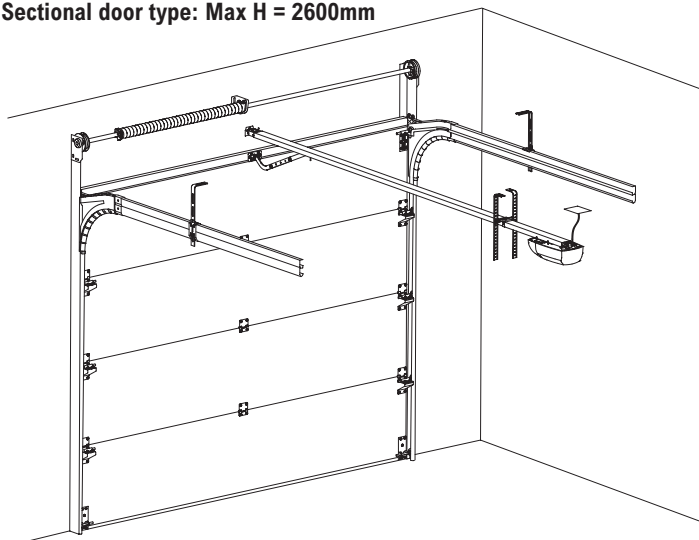

Overhead door type: Max H = 2600mm

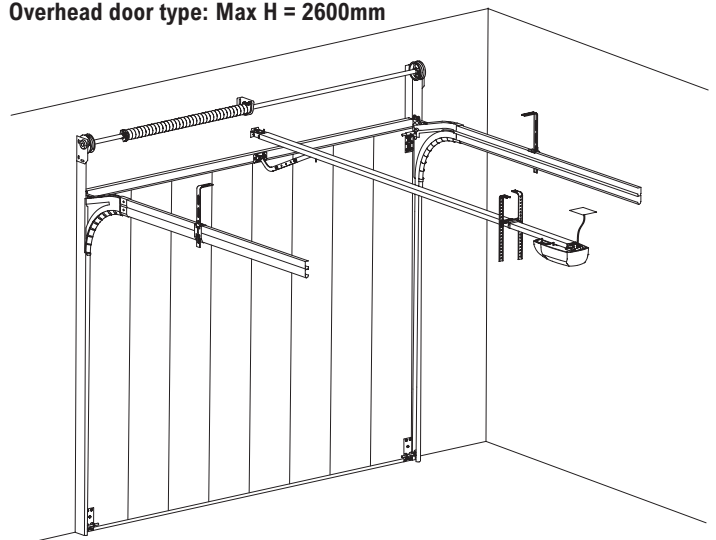

5.1 Assembling the rail

- 1) Cut away the plastic protection of the pulley (Fig. 2) at the end of rail **segment B** (Fig. 1).
Pay attention not to lose the motor adapter inside the pulley. Store it in a safe place for later fitting.

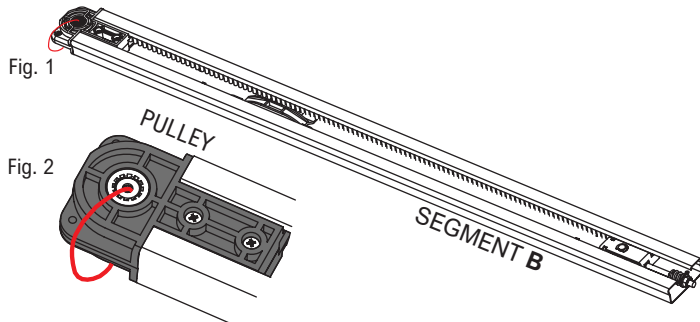

- 2) Slide the rail connector onto the rail **segment B** (Fig. 3) and then slide the trolley into rail **segment C** (Fig. 4). The trolley comes with a built-in pivot and a pin. Make sure that they face the fixed bracket at the rail **segment C**'s end.

IMPORTANT NOTE:

The trolley must be mounted into the rail at this stage of the procedure. Once the rail is fully assembled, you will no longer be able to insert the trolley into the rail.

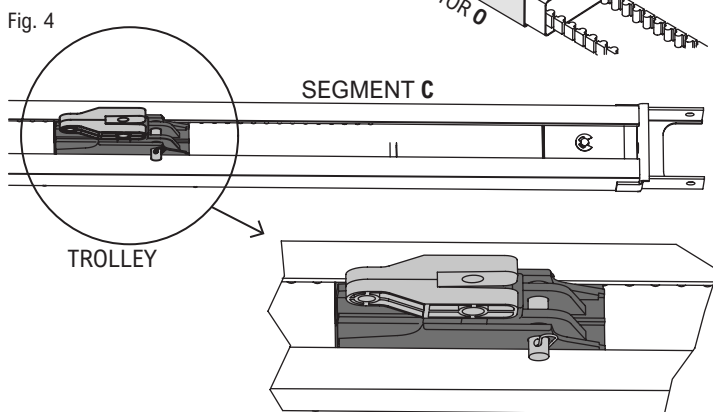
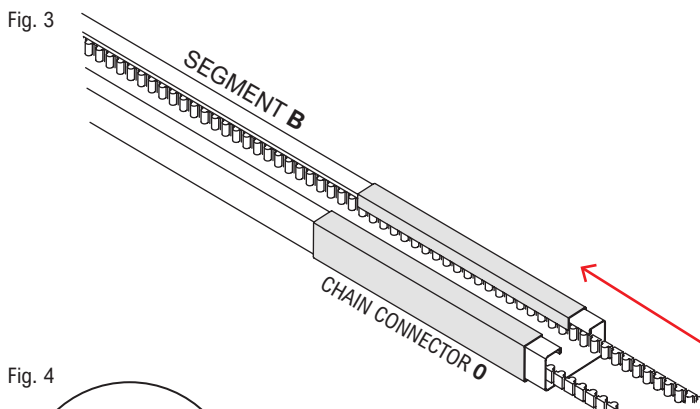

- 3) Joint together rail **segments B** and **C** using the chain connector **O** (Fig. 5 and 6).

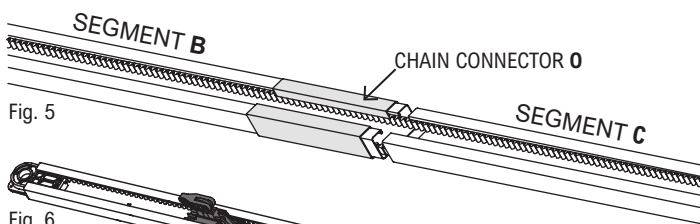

- 4) Slide the belt tensioner from rail **segment B** to the opposite end of rail **segment C** (next to the fixed bracket).

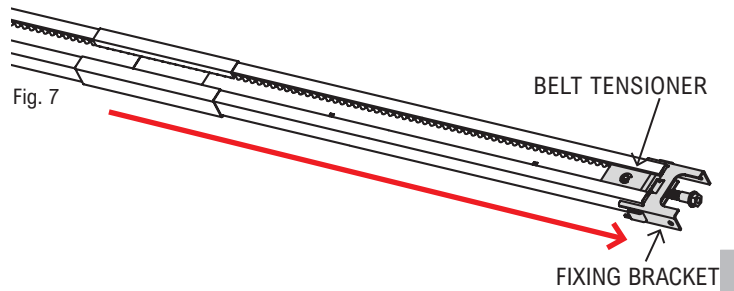

5.2 FITTING THE BELT TENSIONER

- 1) On the fixed bracket at the end of rail **segment C**, you can see a screw with a spring. (Fig. 7).
- 2) Screw the belt tensioner as shown in Fig. 8.
- 3) Fasten the screw and spring as per distance shown in Fig. 9.

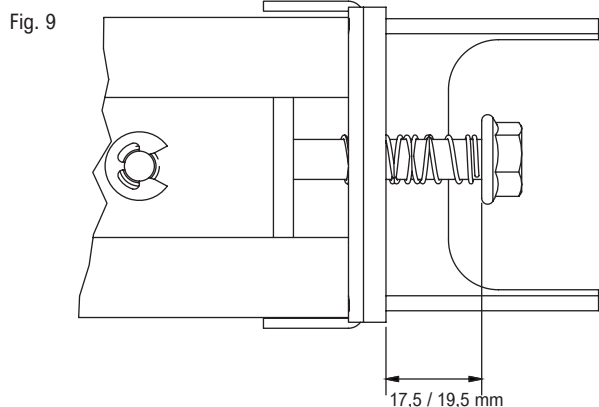
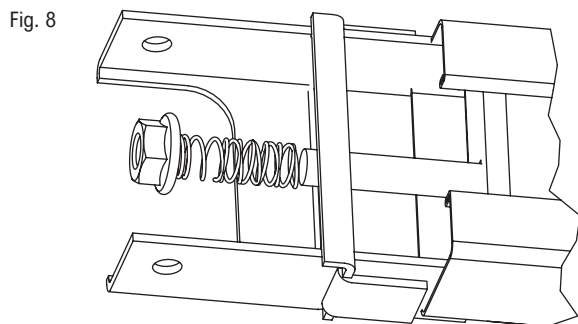

5.3 Fixing the wall bracket and the rail

- 1) Remove the door locking system.
- 2) Place the door bracket as central as possible on the wall over the door. Keep a minimum distance from the upper edge of the door's frame of about 10 cm (Fig. 10).

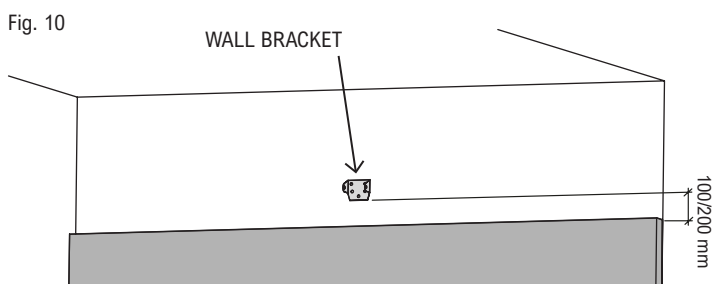

- 3) Anchor the bracket to the wall.

- 4) Lay the rail face down on the floor and make a mark on the rail at the distance shown in the Fig. 11.
The length of the rail depends on the garage door opener model you have: check your model to detect the right quote.

DOLLY 600 (3005 mm) = 2200 mm / 2600 mm
DOLLY 1000 (3205 mm) = 2350 mm / 2770 mm
DOLLY 1200 (3505 mm) = 2570 mm / 3030 mm

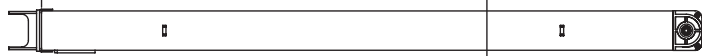
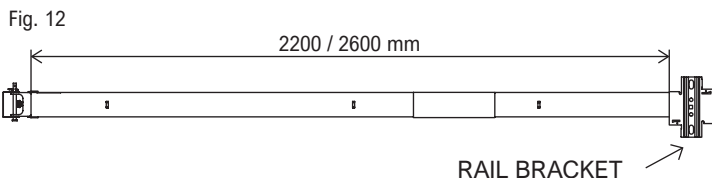

Fig. 11



- 5) Mount the rail bracket on the rail at the marked point (Fig. 12).

- 6) Lift the fixed bracket at the end of the rail to the wall bracket previously anchored (Fig. 13).

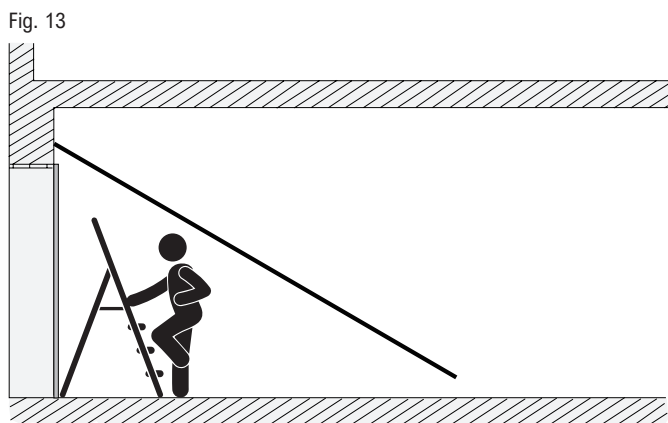

Fig. 13

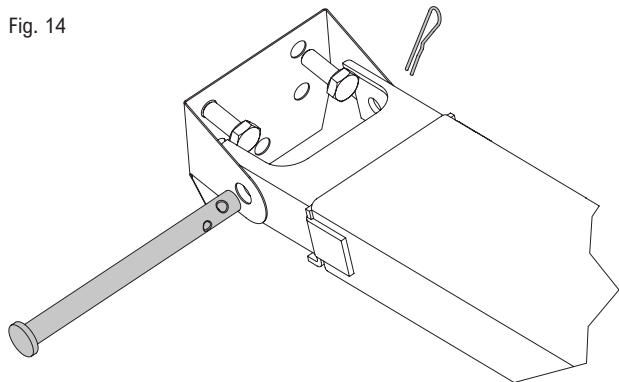

Fig. 14

- 7) Attach the rail to the wall bracket using the pivot and pin coming with the bracket (Fig. 14).
 8) Take the ceiling-mounting bracket and lift the other end of the rail up (Fig. 15).
 9) Choose the correct hole of intersection for the ceiling mounting bracket and the rail and use the upper slot of the ceiling-mounting bracket to mark the fixing point on the ceiling.

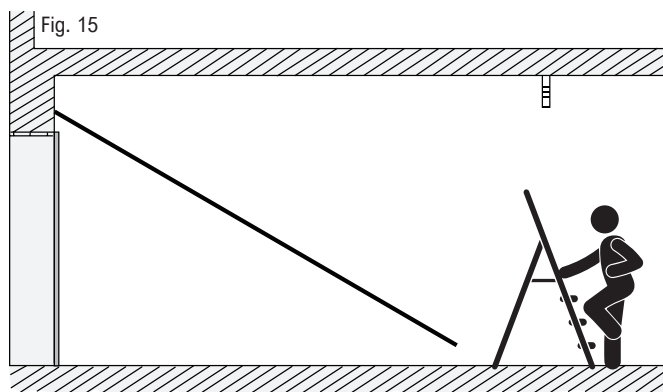

Fig. 15

Fig. 16

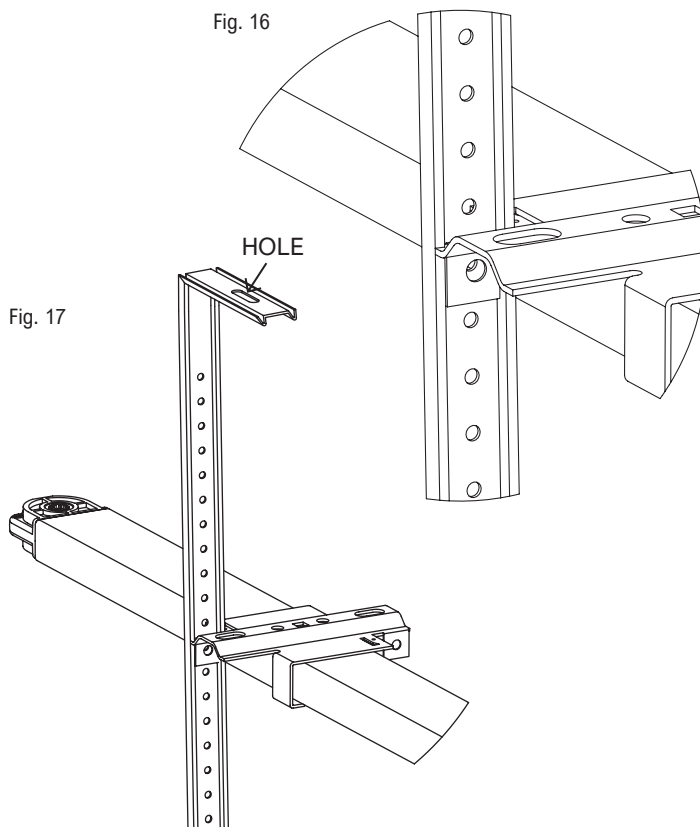
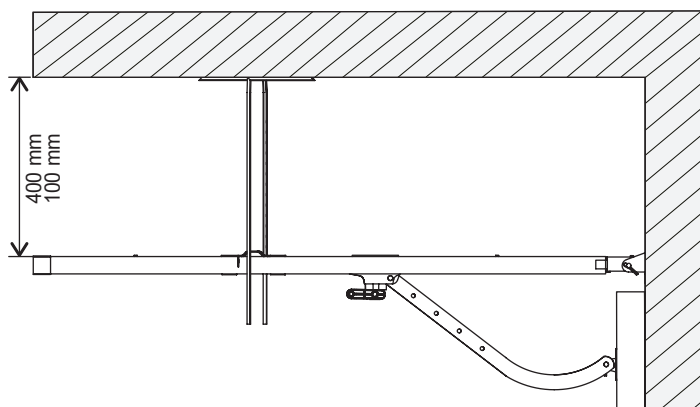

Fig. 17

Fig. 18



- 10) Please refer to quotes shown in Fig. 18 for a proper installation of the rail.

- 11) Bring the rail end and the ceiling bracket down again and cut away the exceeding part of the ceiling bracket (as shown in Fig. 19). Repeat the procedure for the other ceiling bracket.
- 12) Fix one of the ceiling bracket to the point previously marked on the ceiling (step 9).
- 13) Lift the opener rail up and fasten to the ceiling bracket at the hole previously chosen (Fig. 20)
- 14) Take the other ceiling bracket up, mark the fixing point on the ceiling, anchor the second bracket to ceiling and make sure it can be fasten to the rail bracket at the right hole.
- 15) Now unfasten the rail from both ceiling brackets and bring it down again to fit the opener.

Fig. 19

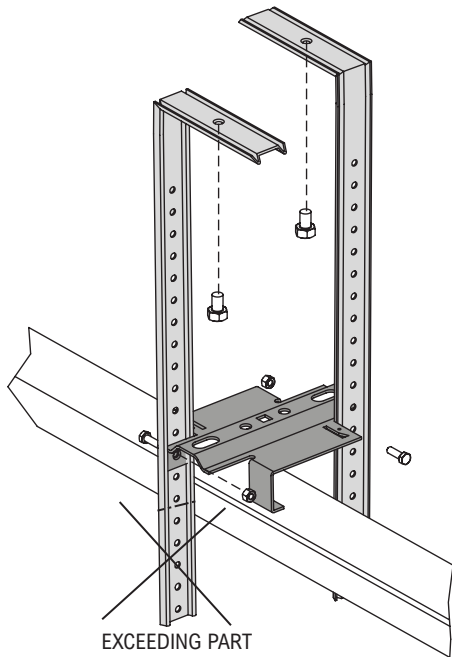

Fig. 20

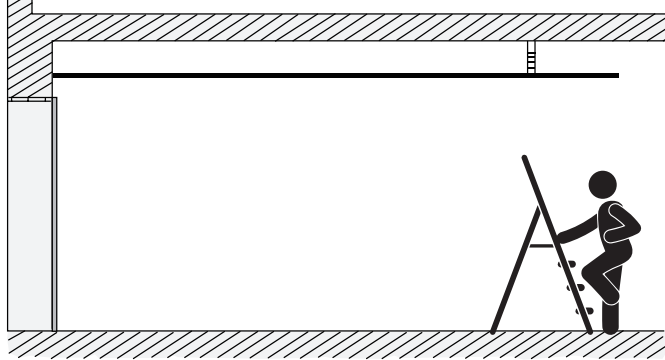

Fig. 21

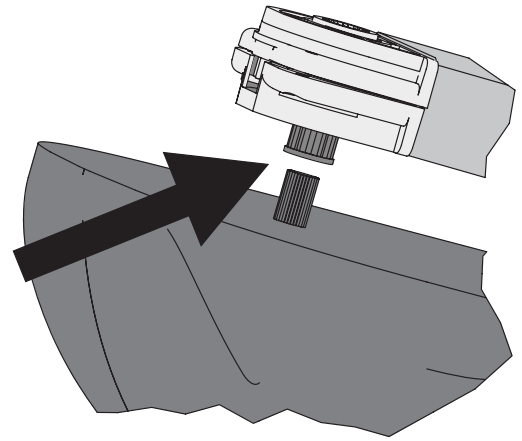

Fig. 22

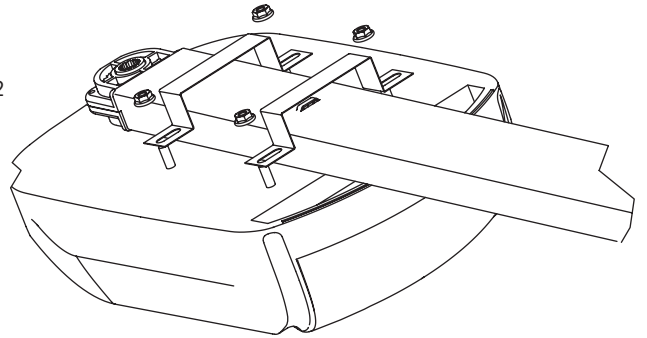

Fig. 23

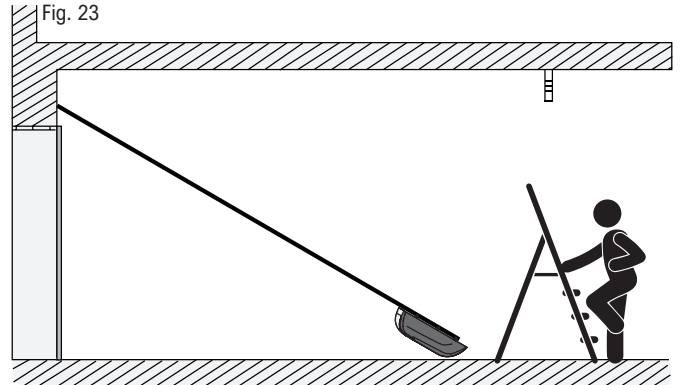

Fig. 24

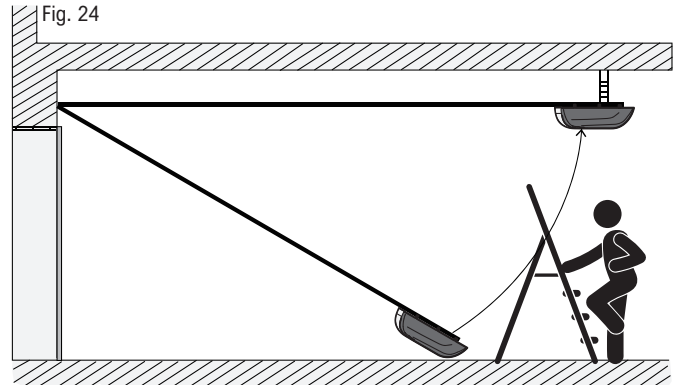
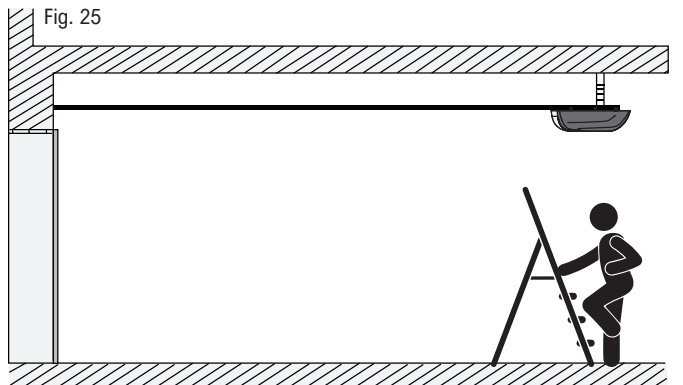

Fig. 25



5.4 Fitting the motor to the rail

- 1) Insert the motor-rail adapter previously stored into the rail and fit the motor (Fig. 21). The motor-rail adapter comes with fail-safe design so that it can be fitted in one-way only.
- 2) Use the two **U brackets** to fix the opener to the rail and fasten with the four M6 nuts you find in the fixing accessories bag (Fig. 22).
- 3) Lift the rail with opener to and fix to the ceiling brackets previously anchored (Fig. 23, 24, 25).

5.5 Assembling the tow brackets

Check the distance between the wall bracket and the upper edge of the door (please refer to Fig. 10 in paragraph 5.3 of this manual). If the distance between the wall bracket and the upper edge of the door is 15 cm or less, use the curved tow arm only to connect the trolley to the door bracket.

On the contrary, if the distance is more than 15 cm you must use both tow arms (curved and straight) assembled together (Fig. 26).

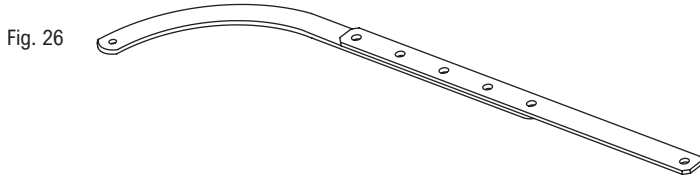

Fig. 26

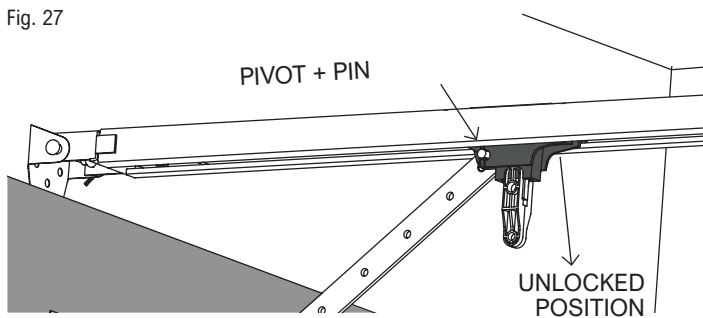

Fig. 27

5.6 Fixing the door bracket

- 1) Use the pivot and the pin on the trolley to connect the assembled tow bracket on the trolley (Fig. 27).
- 2) Fasten the other end of the tow bracket to the door bracket and unlock the clutch of the trolley pulling the handle down (fig. 28).
- 3) Slide the trolley with the assembled tow bracket and door bracket until you reach the door (closed).
- 4) Fix the door bracket to the door. Please refer to recommended fixing quotes as per Fig. 29.
- 5) Tie the release cord with knob the clutch handle of the trolley (Fig. 30).

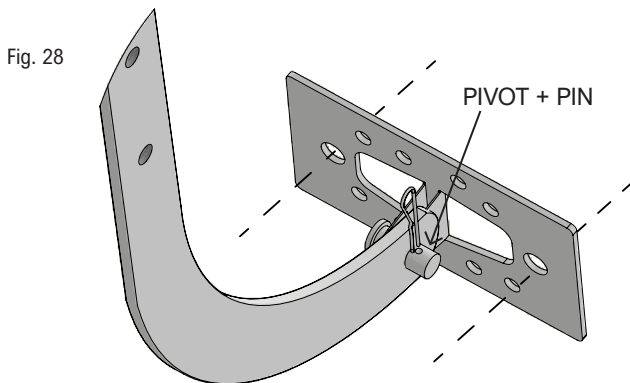

Fig. 28

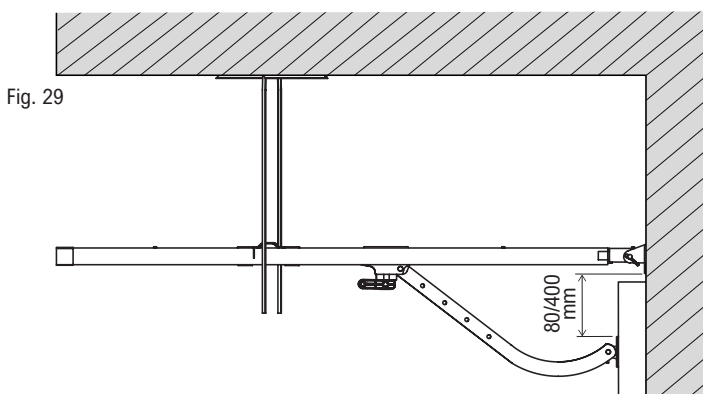
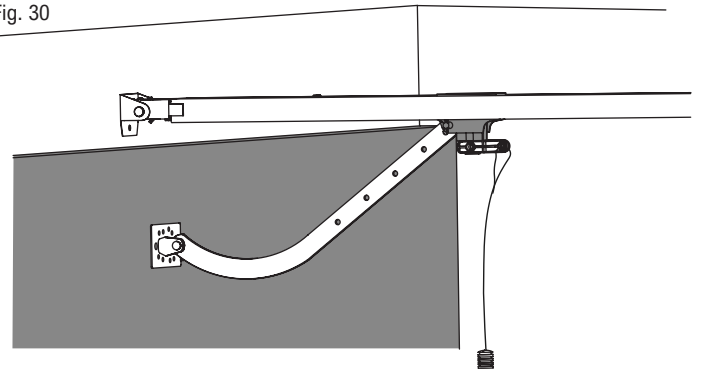

Fig. 29

Fig. 30



6. COUNTER-WEIGHTS BALANCED OVERHEAD DOORS

For protruding overhead doors, counter-weights balanced **ARC02** adapter arm is needed (Fig. 31).

ARC02 adapter can be purchased as option accessory and shall be assembled as shown in Fig. 32.

Use the straight tow bracket to connect the **ARC02** adapter arm to the trolley. For further details, please refer to **ARC02** manual.

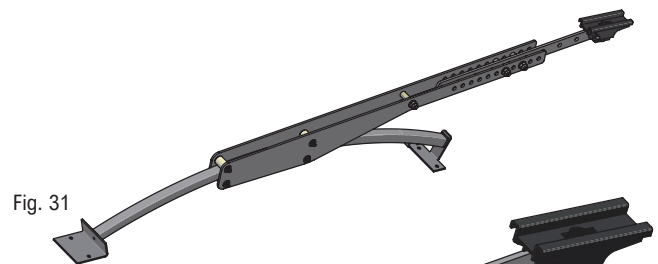

Fig. 31

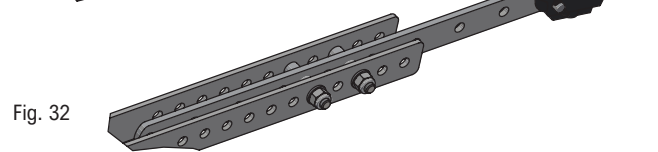

Fig. 32

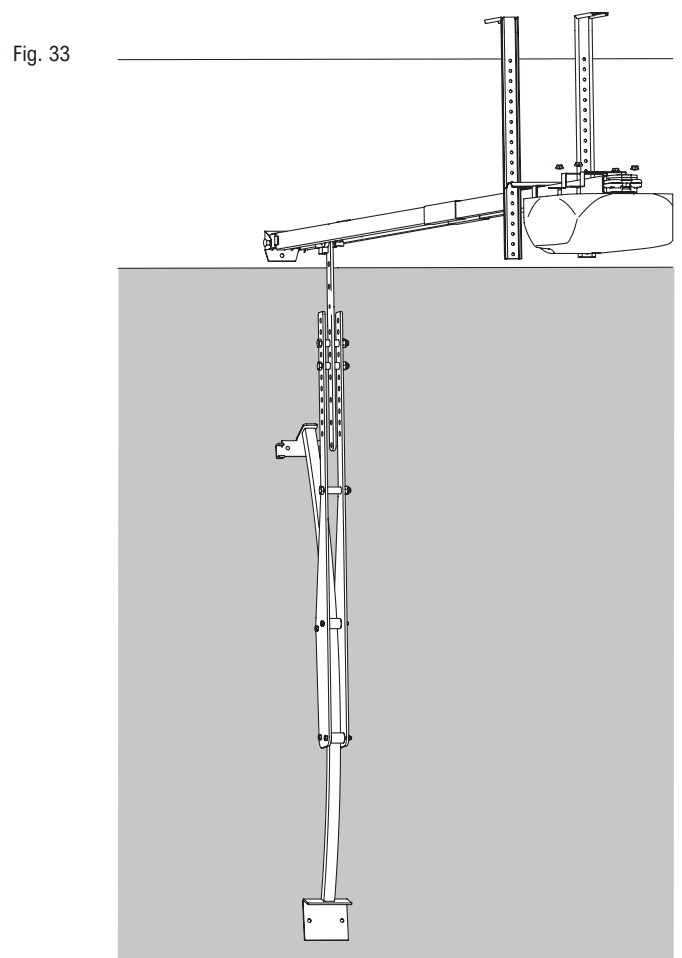

Fig. 33

7. MANUAL RELEASE

This garage door opener is equipped with an emergency release system (Fig. 34) to allow the user to open manually the door in case of breakdown or power-cut.

Pull the release cord down to disengage the clutch.

To lock again the system move the door automatically or manually up and down until the clutch re-engages back in locked position.

If your garage does not feature any other secondary exit, we recommend installing an emergency release system from outside. Please refer to optional accessory shown in Fig. 35/36.

Fig. 34

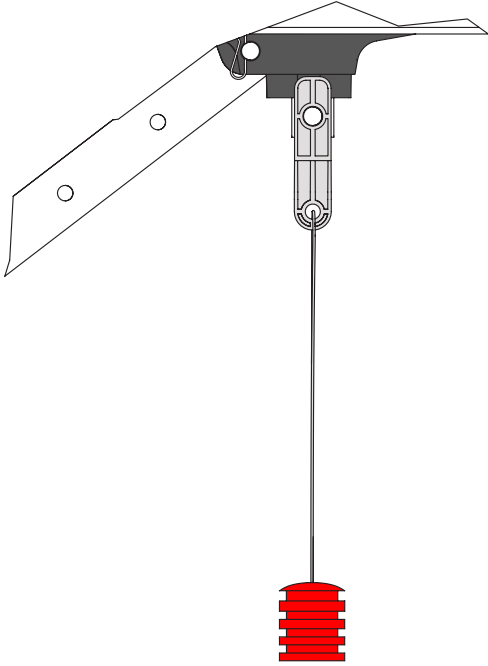

Fig. 35

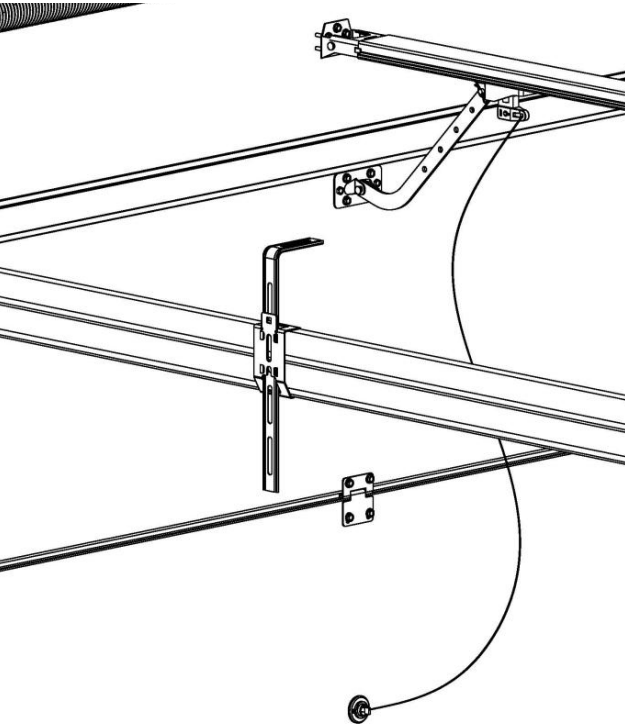
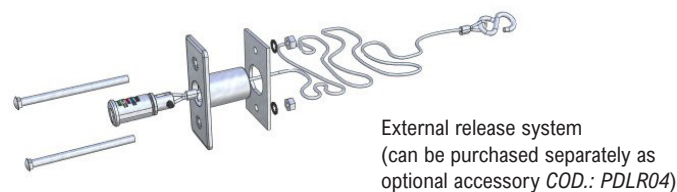

Fig. 36



8. PROGRAMMING

8.1 Setting the door opening and closing position. Auto-setting of the lifting force

Press “SET” key and hold on until the display show ‘1’.

Release and use the “UP” key to move the door to open position; use “UP” and “DOWN” keys to find the perfect open position of the door and then press again “SET” to confirm the setting: the display will show “2”.

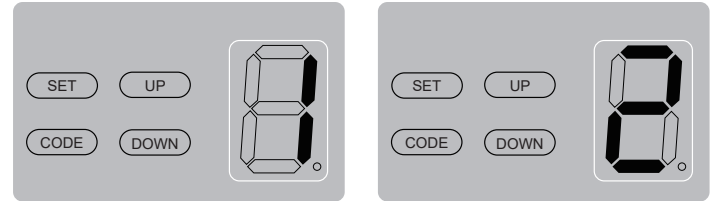

English

Now press “DOWN” key to close the door and use “UP” and “DOWN” keys to find the perfect closed position of the door.

Now press the “SET” key one more time: the door automatically completes an opening and closing cycle to memorise the limit positions.

The opener will automatically setting the force level needed to correctly operate the door.

8.2 Saving/Deleting transmitters radio code

Press the “CODE” key until a red flashing dot shows up in the display bottom corner (Fig. A).

Now press the key of the radio transmitter to save the radio code on the receiver: the flashing dot turns off; now press once again the key of the radio transmitter: the red dot flashes again quickly and then the display shows the letter “u” (Fig. B) to confirm that the radio code has been correctly saved in the receiver’s memory card.

You can now use the transmitter’s key to open/close/stop the garage door.

Fig. A

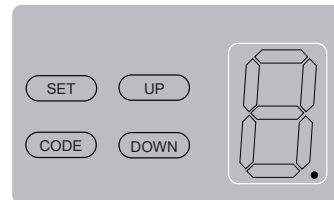
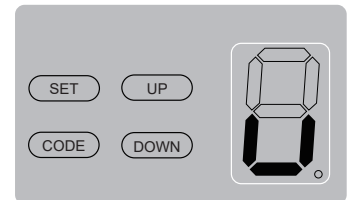

Fig. B



To delete all radio codes previously saved in the receiver’s memory card press and hold the “CODE” key for at least 8 second (you see the red dot flashing during this time) until the display finally shows the letter “C”.

All radio codes have now been deleted form the receiver’s memory card.

8.3 Start command

You can connect a Start command device (i.e. wall push-button, key-switch, keypad, etc...) to control the opener (open, stop, close) without using the radio transmitter.

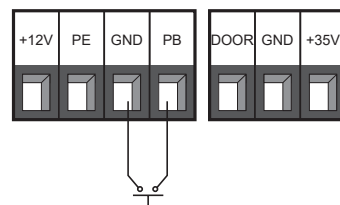

8.4 Reset to factory settings

Press and hold the “**SET**” key browsing the menu until the display shows the letter “**A**” and then release the key.

- If you want to confirm the reset to factory settings, press “**SET**” key once again.
All settings return to factory standard (but the receiver’s memory card has not been deleted so any radio transmitter previously saved will continue to work properly).
- If you do not wish to confirm the reset to factory settings **wait for at least 20 seconds** without pressing any keys.
The control unit automatically times out and returns to stand-by mode.

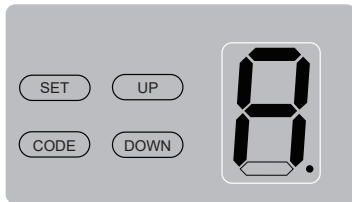

8.5 Obstacle detection adjusting

Press and hold the “**SET**” key, let the display browse the menu until it shows number “**3**” and then release the key.
Use “**UP**” and “**DOWN**” keys to adjust the force/obstacle detection sensitivity.

Level 3 = Maximum force, Minimum sensitivity
Level 1 = Minimum force, maximum sensitivity

Press “**SET**” key again to confirm the adjustment.

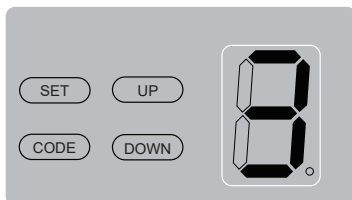

8.6 Auto-closing

Press the “**UP**” key and hold until the current pause time before auto-closing (factory setting is 0 = auto-closing function OFF) and release.

Use “**UP**” and “**DOWN**” keys to increase or the decrease the auto-closing pause time.

Auto-closing time levels range from 0 to 9; **each level = 15 seconds**.
Level 0 = auto-closing OFF

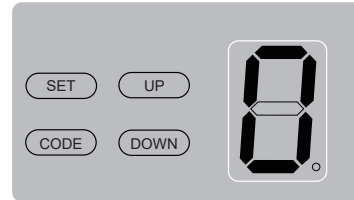

8.7 Enabling the photocells

Press and hold “**DOWN**” key until the display shows “**II**” and release.

Use “**UP**” key to set the Photocells function ON: display shows letter “**H**”.

Use “**DOWN**” key to set the Photocells function OFF: display shows “**II**”.

Press “**SET**” key to confirm your settings.

NOTE: If the Photocells function is ON but there are no photocells wired or photocells are faulty the door will not move for safety reasons until repairing or setting adjustment is performed.

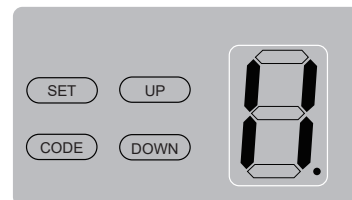

9. WIRINGS

Fig. 37 - PHOTOCELLS NO/NC

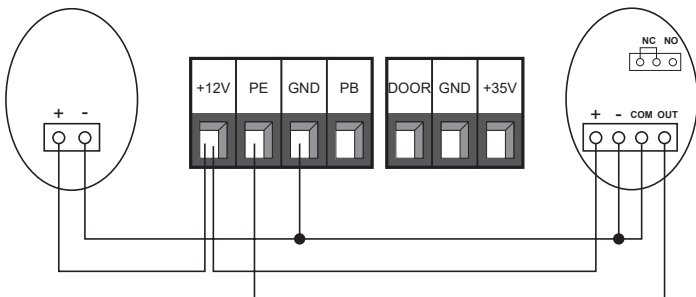

Fig. 39 - Flashing light 24V DC

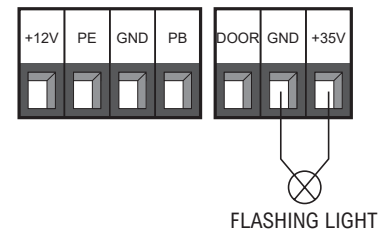
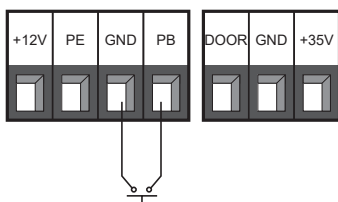
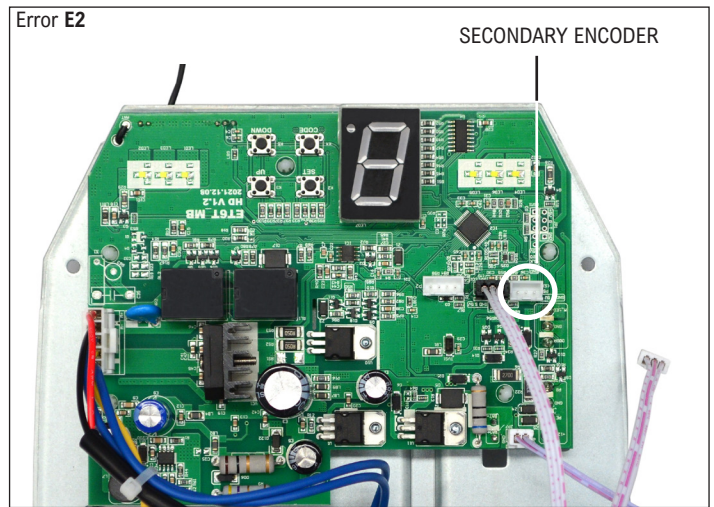
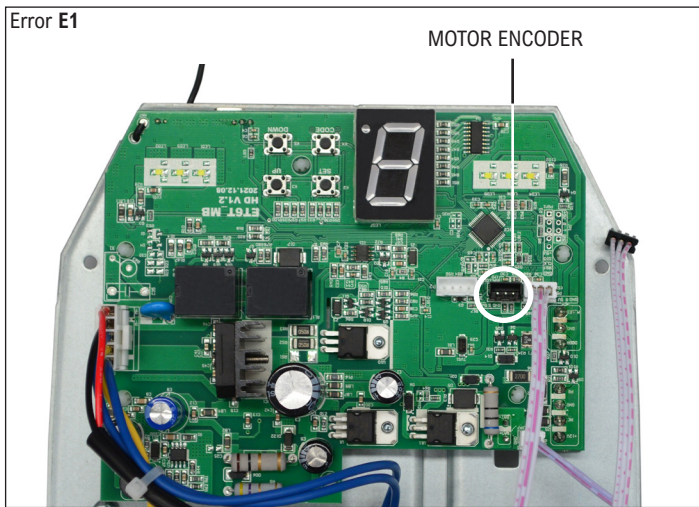

Fig. 38 - START command NO



10. TROUBLE-SHOOTING

ERROR CODE	PROBLEM	POSSIBLE CAUSES	RECOMMENDED CHECKS
E1	Motor encoder	- Motor encoder is not well connected (see picture E1)	- Check wiring between motor encoder and the control unit
E2	Secondary encoder	- Secondary encoder is not well connected (see picture E2)	- Check wiring between secondary encoder and the control unit - Disconnect the control unit from mains and power back again
E3	Secondary encoder prevails on motor encoder	- Motor encoder and secondary encoder wirings are reversed	- Reverse wiring of encoders to the control unit and repeat programming procedure
E4	Switch for the pedestrian door	- Pedestrian door is open - Pedestrian door's wire not well connected	- Close pedestrian door - Check pedestrian door connections and plugs
E5	The opener doesn't run	- Opener's model not suitable to the door's weight - Faulty motor	- Replace opener with a more powerful model - Replace opener
E6	The door stops mid-way when closing	- The opener is detecting an obstacle in its path - Friction between the door and the rail ba	- Remove the obstacle - Fix rail properly and repeat limit positions programming procedure



11. MAINTENANCE

The electronic control unit does not require any maintenance.

We recommend instead a six-monthly check of the door: pay particular attention to the correct balancing of the door and make sure that all drive mechanisms are in good order.

Test obstacle detection reaction every six months, if needed re-adjust the force/obstacle detection setting.







Periodically check that all optional safety devices connected to the system are working properly (photocells, etc.)

Important note:
installation on unwell balanced doors, doors with frictions or not opening/closing smoothly can reduce the life span of the opener due to unbalanced workloads and therefore void the warranty on the product.

12 INSTRUCTIONS FOR END USER

Please read carefully the following instructions as they're essentials to your personal safety, to safeguard your properties and for compliance to applicable laws.
Store this manual in a safe place for future reference.

12.1 WARNINGS

-  Keep all automation controls out of reach for children aged 8 or younger.
-  The product is not intended for use by persons, including children aged 8 or older, with limited physical, sensory or mental capacities, or who lack experience or knowledge, unless supervised or trained in the use of the product by a person responsible for their safety.
-  This product is intended for use only as described in this manual.
Any other enforcement or operation that is not mentioned is expressly prohibited, as it may damage the product and put people at risk causing serious injuries.
-  If the automation shows any signs of anomalous behaviour, disconnect the power supply to the system and manually unlock the motor (see instructions at the end of the chapter) to manoeuvre the automation manually.
Do not attempt any repairs personally, but contact your trusted installer.
-  Remote control devices (radio transmitters, etc....) must be used only when the door is in complete and safe sight.
-  Do not allow children to play with the automated door or with the opener's control devices.

12.2 EMERGENCY RELEASE

Fig. 40

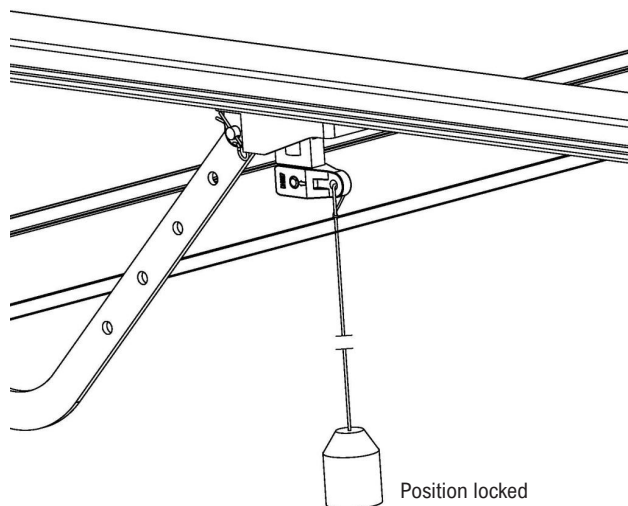
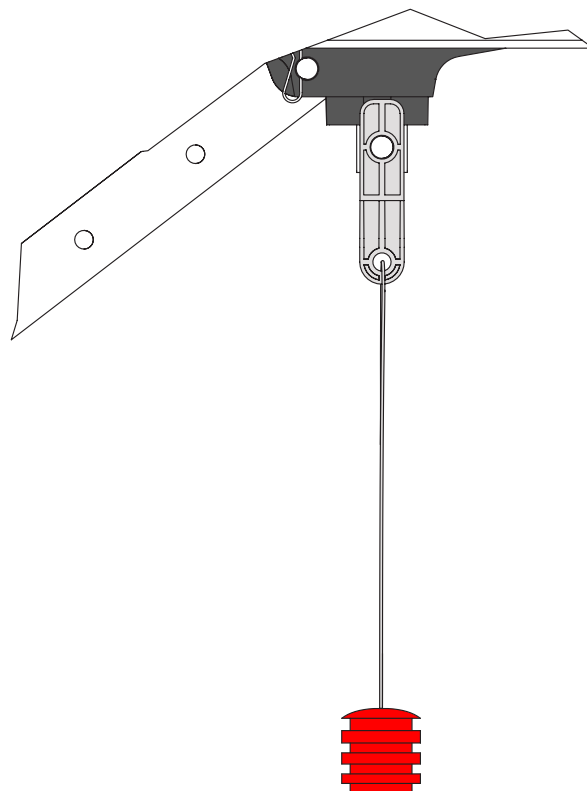
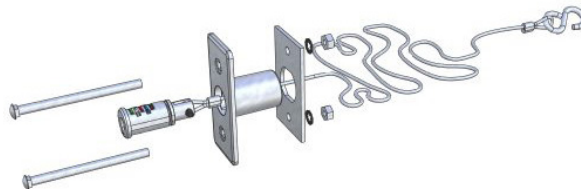

Fig. 41



EXTERNAL RELEASE SYSTEM



13 WARRANTY TERMS

PROTECO products are covered by a 3-year limited warranty from the manufacturing date label on the product.

In this period, Proteco Srl responds for malfunction due to construction faults, faulty parts or faulty assembly.

The guarantee is liable only if use, maintenance and instructions have been duly complied.

This warranty does not respond if non-original spare parts are used or if fault is due to incorrect installation or force majeure conditions. Installation and maintenance are entirely at the installer care and responsibility.

Under no circumstances and in no way Proteco Srl will be liable for damages, loss of profits, savings or other accidental or indirect damages, deriving from the use or from the inability to use PROTECO products.

Any return without a return authorization number will be rejected. Shipping of the returned product and related costs are responsibility of the buyer.

All defective products must be returned along with proof of purchase to: PROTECO Srl Via Neive 77, 12050 Castagnito (CN) - Italia

Warranty is void when:

- The product has been handled/stored under improper conditions of use and maintenance.
- The product has been repaired, modified or altered.
- The product has been subjected to misuse, negligence, electrical problems, and storage in improper packaging, accident or natural events.
- The product was installed improperly.
- The product warranty label is illegible or completely missing.
- The malfunction is due to improper installation or natural and/or accidental causes (e.g. falls, oxidation, and overvoltage).

When returning a product, remember to include in addition all your data (name, surname, address, telephone number and/or e-mail) to allow us to contact you and update you on your return procedure.

14. DISMANTLING AND DISPOSAL

DISPOSAL OF THE SYSTEM

Any part of the system, including devices such as remote controls, must be disposed in compliance with current legislation, as they may be harmful to the environment.

Most of the materials used are similar to solid urban waste and can be handled accordingly.

They can be recycled through separate collection and disposed in authorized centres.

Other components (electronic boards, batteries, etc.) may instead contain polluting substances: you must therefore remove them and deliver to companies authorized for their recovery and disposal.

Before proceeding, it is always advisable to check the specific regulations in force.

DISPOSAL OF PACKAGING

Packaging components (cardboard, plastics, etc.) are similar to solid urban waste and can be handled accordingly, simply by carrying out separate collection for recycling.

Before proceeding, it is always recommended to check the specific regulations in force.

DO NOT DUMP, PROTECT THE ENVIRONMENT!

CE COMPLIANCE DECLARATION

The Manufacturer: **PROTECO S.r.l.**
Address: Via Neive, 77 - 12050 CASTAGNITO (CN) - ITALY
Declares that
The product type: Garage door automatic opene **DOLLY**
Model: **DOLLY 600 - DOLLY 1000 - DOLLY 1200**

Is designed to be integrated into a machine or to be assembled with other machinery to create a machine under provisions of 2006/42/EC Machinery Directive

It complies with the essential requirements of EEC Directives:
Machinery Directive 2006/42/EC (Annex I, Chapter 1)
Directive 2014/53/EU (RED)

- Health protection standards (art. 3(1)(a)) EN 62479:2010
- Electrical safety (art. 3(1)(a)) EN 60950-1.2006+A11:2009+A12:2011+A2:2013
- Electromagnetic compatibility (art. 3(1)(b)) EN 301 489-1 V2.1.1:2017, EN 301 489-3 V2.1.1:2017
- Radio spectrum (art. 3(2)) EN 300 220-1 V3.1.1:2017, EN 300 220-2 V3.2.1:2018

Directive ROHS-3 2015/863/EU

The product also complies with the following standards:
EN 60335-1:2012+A11+A13+A14+A2+A15
EN 60335-2-95:2015+A1+A2
EN 62233:2008

The manufacturer declares that the start-up of the machinery is not permitted unless the machine, in which the product is incorporated or of which is becoming a component, has been identified and declared as conformed to 2006/42/EC Machinery Directive

Note: These products have been tested in a typical homogeneous configuration

Castagnito, July 30 2024

Marco Gallo
CEO

